

Organizational Change and the Dynamics of Innovation: Formal R&D Structure and Intrafirm Inventor Networks*

Nicholas Argyres[†]

Luis A. Rios[‡]

Brian S. Silverman[§]

Abstract: Prior research has argued and shown that firms with centralized R&D organization structures produce broader-impact innovations relative to more decentralized firms. The organizational mechanisms underlying this relationship, however, are underexplored. A better understanding of these mechanisms is needed in order understand whether and how formal R&D structure can be used as a lever to influence research outcomes in the firm. To address these questions, we study the relationship between formal R&D structure, internal inventor networks, and innovative behavior and outcomes. We find that centralization of R&D budget authority increases the connectedness of internal inventor networks, which in turn increases the breadth of impact of innovations and the breadth of technological search. Our results suggest that changes in structure influence innovation outcomes through changes in inventor networks, with a lag reflecting organizational inertia.

JEL Classification: D23 D83 L22

Keywords: Organizational Structure, Innovation, Social Networks, R&D

*Authors contributed equally and are listed in alphabetical order. We thank Ashish Arora, Andrew Shipilov, Michaël Bikard and Seth Carnahan for helpful comments on earlier drafts. We are grateful for valuable feedback from seminar participants at Duke University, University College Dublin, University of Colorado-Boulder, University of Michigan, University of Pennsylvania, and University of Southern California. Expert coding assistance was provided by Rodrigo Aldecoa. We acknowledge generous financial support from the Social Sciences and Humanities Research Council of Canada and the William and Phyllis Mack Institute for Innovation Management.

[†]Olin School of Business, Washington University in St. Louis. Campus Box 1156, St. Louis, MO 63130 argyres@wustl.edu

[‡]Corresponding author. Wharton School of Business, University of Pennsylvania. 3620 Locust Walk Philadelphia, PA 19104. luisrios@upenn.edu

[§]Rotman School of Management, University of Toronto. 105 St. George Street, Toronto, Ontario, Canada M5S 3E6 silverman@rotman.utoronto.ca

INTRODUCTION

The unquestionable importance of innovation has spurred a broad and diverse literature in strategic management. A small but influential stream of this work has argued that a firm's formal R&D organizational structure should affect the type of innovation produced (Birr, Hounshell & Smith, 2006; Kay, 1988; Teece, 1996). Consistent with this, empirical investigations have found that distinct organizational forms are indeed associated with different patterns of innovation (Argyres, 1996; Argyres & Silverman, 2004; Arora, Belenzon & Rios, 2014). However, these latter studies have been limited to showing static, cross-sectional associations between organization structure and innovation outcomes. We thus lack even preliminary evidence about the mechanisms or channels underpinning such relationships, which hampers the development of theory and of normative guidance. This study addresses these limitations by empirically investigating one channel through which changes in formal R&D structure may affect innovation: changes in the structure of the firm's internal inventor network.

While prior work has studied inventor networks, it has not investigated the ways in which collaboration networks within a firm might be shaped by choices of formal R&D structure – a question that is highly relevant for strategic management given its interest in the active management of innovation. For example, prior studies have focused on relationships between network attributes and various types of innovation or innovative activity, or on how an individual inventor's network position impacts her and/or her colleagues' innovation (Obstfeld, 2005; Reagans & Zuckerman, 2001; Grigoriou & Rothaermel, 2017). Indeed, relatively few studies have documented the determinants and consequences of network change in general (Ahuja, Soda & Zaheer, 2012).

To address this gap, we examine the relationship between changes in firms' formal R&D organization structures, which we observe through changes in the loci of R&D budget authority, and subsequent changes in firms' internal co-patenting networks. We also examine the relationship between changes in these internal networks and key firm-level innovation outcomes. Using whole-

network topology measures (Amburgey, Al-Laham, Tzabbar & Aharonson, 2008), we capture the structure of collaboration at the level of the entire organization, rather than from the perspective of individual inventors as much prior work has done. While we are not able to empirically establish causation in the relationships we study, we are able to track a large subset of all U.S. publicly-traded, innovation-oriented companies over a 20-year period, and to document important patterns in the relationships between budgetary control, inventor networks, and innovative output. To our knowledge, no prior work has systematically documented the relationships between formal organization structure and collaboration networks, despite recent calls to do so (McEvily, Soda & Tortoriello, 2014).

Our findings are as follows. First, increased centralization of R&D budget authority is associated with the emergence of new collaborations among researchers who had not previously patented together. Specifically, such centralization is associated with greater connectedness of the firm's co-invention network; that is, a larger fraction of researchers become connected to other researchers through co-invention of a patented innovation (Amburgey et al., 2008). (We describe our formal measures of network connectedness in the empirical section below.) Second, greater network connectedness in turn is associated with an increase in the breadth of innovative search and impact exhibited by a firm's patents. Surprisingly, we find that the reverse may not hold—decentralization does not seem to have much of an effect on either networks or innovation. Finally, we provide novel facts that speak to the mechanisms through which network connectedness mediates the relationship between changes in formal R&D structure and innovative outcomes. We find that roughly 13%-18% of the relationship between budgetary structure change and differences in innovation output is attributable to changes in the informal inventor network, and that these patent changes occur in tandem with the evolution of the co-invention network. Together, these findings suggest that a change in the firm's formal R&D structure triggers a gradual change in its inventor network, which in turn leads to changes in the nature of the firm's innovations.

THEORY AND HYPOTHESES

We bridge the R&D organization and the innovation networks literatures to suggest two broad underlying mechanisms that may interact to drive the organizational dynamics of innovation. These mechanisms correspond to two major views of the firm that are not often reconciled: the firm as an authority-based incentive system in which employees respond to changes in authority and incentives (Holmstrom & Milgrom, 1994; Simon, 1947; Williamson, 1985); and, the firm as a system that transfers knowledge via social capital (Nahapiet & Ghoshal, 1998; Zander & Kogut, 1995), where organization structure affects outcomes through the ways that it guides knowledge flows (Leiponen & Helfat, 2010; Karim & Kaul, 2015).

The Organization of R&D

Prior literature has conceptualized a firm's R&D as centralized if lab directors report to corporate management, and decentralized if they report to divisional management (hybrid R&D organizations involve both types simultaneously). Researchers in centralized structures are motivated to produce innovations that benefit the firm as a whole, while those reporting to divisions or business units are thought to be concerned with division- or unit-specific innovations (Kay 1988). These motivations presumably reflect a desire to defer to authority in order to advance one's career, and to respond to any financial incentives that accompany the reporting structure.

R&D organizational choices have been shown to affect the nature of a firm's innovative efforts and outcomes. For example, multidivisional firms whose R&D activities are centralized tend to invest more in R&D, to generate more scientific publications, and to produce more patents per R&D dollar (Arora et al., 2014). This has been interpreted to mean that such firms' strategies emphasize internal R&D and patenting more than firms whose R&D is decentralized or hybrid in form. Centralized firms also produce innovations with larger and broader impact on the economy generally, as reflected in patent citations (Argyres & Silverman, 2004). This effect is believed to stem from the fact that centralized R&D incentivizes researchers to produce innovations that are applicable to the firm broadly, rather than to the product lines of their single, pre-specified

division or sub-unit (Birr et al., 2006; Kay, 1988). Thus innovation in centralized R&D units might aim at entirely new products over which no division has yet been assigned authority. Managers of product or geographic divisions, conversely, often have weaker incentives to invest in fundamental, non-specific R&D that might benefit other divisions of the firm (Argyres, 1996; Hoskisson, Hitt & Hill, 1993). Consistent with this logic, firms with multiple R&D locations (which is usually associated with more decentralized R&D) have been found to produce relatively imitative innovations (Leiponen & Helfat, 2010).

A firm's R&D organizational structure can also affect the ways in which its researchers undertake technological search. If, as discussed above, centralized R&D makes researchers more accountable and responsible for producing innovations that benefit multiple divisions within the firm, or that lead to new firm divisions, they are likely to search more broadly for inputs into the innovation than if they are responsible for one division's domain only (Argyres & Silverman, 2004). Decentralized R&D, on the other hand, will be associated with narrower search, either because it makes researchers more accountable to division managers for funding, or it reflects the more limited and division-specific communication channels in which they become embedded (Henderson & Clark, 1990).

The foregoing suggests clear implications for organizational dynamics: Centralizing budget authority should lead to more non-specific (broader) knowledge that can potentially apply to multiple divisions of the firm. Conversely, firms that decentralize their R&D should produce innovations that have narrower impact than before the change. Yet, despite the intuitiveness of these extrapolations, there is no work to our knowledge that has systematically documented such dynamic relationships. Aside from a handful of suggestive case studies, such as Hounshell and Smith's seminal history of DuPont (1988), we still know very little about how changes in the structure of R&D affects firm innovation. This paucity of research reflects the fact that organizational structure remains stubbornly difficult to observe, and remains a "neglected" pillar of organizational research (Gavetti, Levinthal & Ocasio, 2007). We argue that inventor networks should play a role in mediating the relationship between formal structure and innovation, and

can provide a valuable window into the dynamics of innovation within firms.

The role of inventor networks

The sociology of innovation has shown that inventor networks play an important role in shaping innovative activity and output (Guler & Nerkar, 2012; Obstfeld, 2005; Reagans & Zuckerman, 2001; Moreira, Markus & Laursen, 2018). Although changes in network structures are sparse in this literature, findings regarding authority, incentives and within-firm social capital suggest that changes in formal R&D structure should affect network structure. Thus, a change in R&D budget authority is likely to lead researchers to seek out new collaborations (or abandon collaborations) in order to secure the funding needed to complete their projects and advance their careers. For example, centralization of R&D budgets may lead divisional researchers to seek collaborations with researchers in other divisions (or in a central lab) with whom they had not previously collaborated, in order to access knowledge of other technological areas of the firm, with the aim of gaining funding from the (now more important) central source. The idea that researchers are able to overcome limitations on their own knowledge (Toh, 2014) by seeking collaborations with others is consistent with evidence that more organizationally proximate researchers are more likely to cite each other's patents in their own patents (Agrawal, Kapur & McHale, 2008; Singh & Mitchell, 2005; Singh & Marx, 2013). Thus, "network-modifying actions by network actors in the present may have consequences for network structure later" (Ahuja et al., 2012, p.435).

This expectation assumes that researchers have some discretion in choosing with whom to collaborate within the firm. Prior work supports this assumption. Literature in organization theory has emphasized that employees, especially those with highly technical expertise, often enjoy discretion in guiding their projects and choosing collaborators because higher-level managers lack the "local" knowledge required to make such fine-grained decisions (Sorenson, Rivkin & Fleming, 2006; Jensen & Meckling, 1992). In the words of Herbert Simon: "A subordinate may be told what to do, but given considerable leeway as to how he will carry out the task" (Simon 1947: 223, italics in original). Thus, while managers may play a role in assigning researchers to broad

areas of research, or perhaps even to large projects, collaborations within these areas or projects are likely to reflect some researcher discretion. Relatedly, inventors rely heavily on social sources of knowledge in their immediate vicinity (Katz & Allen, 1982) and inventors' networks strongly influence subsequent productivity, especially where tacit knowledge is important (Fleming, Mingo & Chen, 2007).¹ Moreover, if experience generates a stock of knowledge, and being exposed to other inventors of the firm increases such knowledge, then it is likely that there is a positive feedback loop between more network connections and increases in the search space.

Centralization, Decentralization, and Network Change

We propose that the search processes described in the foregoing are enabled and constrained by an inventor's network connections. Following R&D centralization, a researcher should become exposed to more of the firm's researchers and their work, as she makes new connections with R&D staff from other units of the firm. Thus formerly disconnected researchers will seek to (or be assigned to) combine their own specialized knowledge with their colleagues' in order to produce more non-specific innovations (we would expect similar and possibly stronger effects if the increase in R&D centralization involves the creation or expansion of a new centralized R&D unit). This will cause the firm's network of patent co-authoring relationships to become more connected, with fewer isolated groups of researchers. We expect the opposite effects from decentralization of the firm's R&D structure. Following R&D decentralization, some marginal projects with broader application will be abandoned, with researchers choosing instead (or being assigned) to work with colleagues in their own, narrower, areas of expertise. Thus, given that R&D decentralization will lead to a less connected (more fragmented) internal inventor network, we hypothesize that:

H1: An increase (decrease) in centralization of a firm's formal R&D structure is associated with an increase (decrease) in the connectedness of its intrafirm inventor network.

¹Consistent with this, Fleming and Sorenson's review of the literature (2004) found that individual inventors search locally both as a function of their own experience and of institutional factors (corresponding, in our case, to directives of top managers). They also provide large sample evidence consistent with this view—in particular, they show that the search space changes as individuals gain more experience, suggesting that inventors have considerable discretion in establishing the search space.

Network Change and Innovation

How will a change in network connectedness affect the average breadth of impact and search of the firm's innovations? It is commonly thought that fundamental innovations tend to emerge from a synthesis of ideas originating in disparate scientific and technological realms (Koestler, 1964; Nelson & Winter, 1982; Schumpeter, 1942). The literature on innovation networks, however, has long debated whether networks featuring closure (facilitating transfer of less dispersed ideas) or brokerage (facilitating transfer of more dispersed ideas) are better at fostering innovation. While numerous studies have found empirical evidence for the positive impact of closure (Hansen, 1999; Obstfeld, 2005; Uzzi, 1997), a commensurate number have found evidence that brokerage yields more impactful innovation (Burt, 2004; Nerkar & Paruchuri, 2005; Rodan & Galunic, 2004).²

We suggest that networks featuring high levels of both closure *and* brokerage will be important in fostering innovation. The combination of the two effects can be captured in the concept of the "connectedness" within the whole network of a firm's inventors (defined formally in the next section). A network is maximally connected if there is a path (however long) between every pair of nodes—inventors—in the network (Wasserman & Faust, 1994). It becomes less connected for every isolated "component" in the network, where a component refers to a group of connected inventors that is not connected to other components³. As the number of components (or "silos") in a network grows, the network becomes less connected: that is, more fragmented. Therefore, networks that are high in connectedness are also high in both brokerage and cohesion, while those low in connectedness are low in both brokerage and cohesion.

The greater brokerage and cohesion in more connected networks should produce innovations with broader impact because they facilitate the sharing and synthesis of ideas. Consistent with this, Guler & Nerkar (2012) found that greater local connectedness of intrafirm networks in pharmaceutical firms was associated with a greater likelihood that a patent would lead to a

²More recently, scholars have moved beyond this debate by studying contingencies on the effects of network structure, such as inventor characteristics (Fleming, King & Juda, 2007) and tie quality (Tortoriello & Krackhardt, 2010).

³See Schilling (2015) for a recent use of the concept of isolates and components in innovation networks.

more consequential innovation (reflected in a commercialized product).⁴ Analogously to our study, but in an interfirm setting, Schilling (2015) found that shocks triggered an evolution towards larger or denser collaboration networks, which in turn had a positive effect on innovation outcomes. Therefore, findings in the innovation networks literature support the hypothesis that more connected whole networks will feature innovation with broader impact:

H2a: An increase (decrease) in the connectedness of a firm's intrafirm inventor network is associated with an increase (decrease) in the breadth of its innovative impact.

Finally, with regard to innovative search, greater whole network connectedness enables inventors to become aware of research that would be remote or inaccessible were the network to consist of more isolated components. Such awareness has been shown to be an important antecedent to the formation of network ties for knowledge exchange (Borgatti & Cross, 2003). This leads to our complementary hypothesis:

H2b: An increase (decrease) in the connectedness of a firm's intrafirm inventor network is associated with an increase (decrease) in the breadth of its innovative search.

DATA

It is difficult to obtain data on formal changes to firms' R&D organizations because such changes are not routinely reported. We overcome this obstacle by taking advantage of an unusual database. The Industrial Research Institute (IRI), an industry trade association for large R&D-intensive corporations, conducted an annual survey of members between 1991 and 2000. This database has been curated and augmented by the Center for Innovation Management Studies (CIMS) at North Carolina State University.⁵ Respondents (typically senior R&D executives) provided information on a number of R&D-related features of their firms. One of the items that was consistently collected throughout this period was the fraction of a firm's R&D budget that was provided by corporate headquarters (and the fraction provided by business units). This information allows us to observe levels and changes in the centralization (decentralization) of R&D in these firms. The locus of budgetary control has been used with a similar interpretation in prior research to

⁴Guler & Nerkar (2012) also found that the innovation benefits of connectedness disappeared when networks become more global. The authors attribute this finding to difficulties of collaborating internationally.

⁵We are grateful to CIMS for sharing these data with us, and to Professor Sarah Kaplan at the University of Toronto for facilitating this arrangement.

measure R&D centralization (Argyres & Silverman, 2004).⁶

While the CIMS/IRI database provides information on more than 130 large corporations throughout this period, not all firms responded every year; therefore we retain only the 96 firms that responded in numerous years, in order to capture potential changes in their structure. Figure 1 shows the extent to which these 96 firms changed their budget allocations during this period. As Panel A shows, roughly one-quarter of the firms made no changes at all, while two-thirds of the firms changed their centralization of R&D by less than 15 percentage points from year to year (i.e., they changed the proportion of R&D funding provided by corporate headquarters by less than 0.15). Seven firms (8%) completely shifted R&D from decentralization to centralization or vice versa. Panel B disaggregates the data to the firm-year level. More than half of the firm-years show zero change in centralization, and nearly 90% report changes that were less than plus-or-minus 10 percentage points. In general, then, relatively few firms exhibit substantial shifts in their R&D budgetary structures over time, and when such shifts do occur, they do so over a small number of years. While changes in R&D structure are clearly due to endogenous choices, it is important to note that our interest is in the organizational mechanisms through which these choices may influence the type of innovation produced, rather than the determinants of the initial choice of structure. Nonetheless, we address the issue of endogenous choice of R&D structure via mediation analyses.

[INSERT FIGURE 1 ABOUT HERE]

We augmented our CIMS/IRI firms by adding all COMPUSTAT firms in the same primary four-digit NAICS that held at least 250 patents during our sample period. The larger panel helps to control for secular industry trends in patenting. Industries experience strong trends and bandwagon effects in their patenting over time (Arora et al., 2014; Hall & Ziedonis, 2001), making it hard to know if firms are changing due to restructuring in response to industry trends.

⁶This conceptualization of organizational structure differs from the spatial dispersion or collocation of inventive activity. It is not clear how spatial arrangements map to the organization and coordination of activity. On the one hand, Leiponen & Helfat (2010) argue for a relatively mechanical relationship between spatial dispersion and decentralization of coordination and control. On the other hand Arora et al (2014) and Singh (2008) point out that control can happen without collocation. We are agnostic to the role of the spatial location of activity because in our paper we focus exclusively on the formal authority as captured by budgetary control.

The larger panel also facilitates the creation of sets of matched control firms for implementing techniques such as synthetic control regression (Abadie, Drukker, Herr & Imbens, 2001) to test the robustness of our results. Our unbalanced panel included 670 firms observed over a period of 20 years.⁷ Our unbalanced panel included 670 firms observed over a period of 20 years.

For the non-CIMS/IRI firms, we assume that they did not undergo changes to R&D budget authority during the observation period. Our logic for this is that such changes are relatively rare. Besides the direct observations reported above for the CIMS/IRI firms, Arora et al. (2014) found that R&D organizational structure was highly stable among a sample of 1,014 firms very similar to ours. We also performed manual searches of public sources for a random sample of the COMPUSTAT firms for evidence of any R&D structure changes during the observation period 1990-2008. We found no evidence of changes. Our data on non-CIMS firms may be somewhat noisy and biased toward recording no change when some change occurred, but this drawback represents classical measurement error, and if large would result in attenuation bias against finding support for our hypotheses. Our empirical section details various tests we ran on these samples.

We used patent data to construct inventor network and innovation measures. We combined data from two sources: patent-level information from the European Patent Office's (EPO's) PATSTAT database, and ownership structure data from ORBIS by Bureau van Dijk (BvD) Using these two relational databases provides some advantages in this setting relative to other sources. A collaboration between the EPO and BvD from 2010 to 2013 facilitated progress in matching a good number of the PATSTAT patents to BvD's corporate ownership database.⁸ Building on this, and following the methodology in Rios (2019), we constructed an inventory of patents, inventors, and ownership structure for each of our firms. This is important in our setting for two reasons. First, we are interested in the collaboration networks of internal scientists, so it is important to exclude acquired patents. Second, wholly owned subsidiaries can often bias samples as patents assigned to subsidiaries might be mistaken for external patents, despite being generated within the

⁷In robustness tests, we limited the sample to only the 96 CIMS/IRI firms. When we estimate models with only the core sample of CIMS/IRI firms, the results are qualitatively similar to those presented below.

⁸<https://www.idener.es/?portfolio=imalinker>

boundaries of the firm (Arora et al., 2014). BvD’s coverage of corporate ownership information helps us mitigate those concerns. Because of such advantages, as well as its global coverage, PATSTAT has been increasingly used by innovation scholars (Arts, Cassiman & Gomez, 2018; Harhoff & Wagner, 2009). Considerable work was required to reconstruct corporate ownership as it existed during the study period, and to disambiguate inventors to a level that was adequate for our analysis. The resulting panel matches all patents, applications, and reassignments between 1980 and 2015 for our firms, their wholly owned subsidiaries, and their acquisition targets.

MEASURES

Inventor networks

To map a firm’s inventor network we use tools from the *igraph* software library (Csárdi & Nepusz, 2014) embedded in and augmented by a set of custom Python scripts. Each inventor is identified as a node, and a tie is recorded whenever an inventor collaborates on a patent application with another inventor within the firm. Observing applications is important, because using granted patents would introduce a lag of 2-3 years on average between the collaboration and the observed link (Gans, Hsu & Stern, 2008), and would miss all collaborations that do not lead to patents. We define ties as non-directional, and networks are mapped for each firm-year, resulting in 7,623 snapshots of network structure for our sample. Because we are interested in the evolution (dissolution) of ties among existing nodes, rather than the addition (deletion) of nodes, we take three steps to mitigate the concern that changes in network topology are driven by inventor mobility. First, we exclude firms that underwent major M&A events during the study period; second, we exclude inventors that did not appear in the sample prior to the change in structure.⁹ Finally, we use a now-discontinued annual guide that reported the locations of American firms’ R&D labs. *The Directory of American Research and Technology* was published for a period that coincides with our study. Data from the directory allowed us to confirm that changes in R&D budget authority did not co-occur with the addition or deletion of R&D labs by changer firms.

As explained above, we are interested in the degree to which the firm’s inventor network is

⁹These results are robust to including inventors who did not appear prior to the change in structure.

characterized by high levels of connections among its inventors. To measure this, we require network-level measures of connectedness.¹⁰ We rely on the *relative giant component size* and the *normalized entropy* of firm j 's network in year t as our measures. Each of these is defined below, but first we explain the logic behind our choices.

Intrafirm inventor networks generally have numerous—in some cases an immense number—of isolated components. This is often not the case in other kinds of networks whose membership by construction is defined by being connected (e.g., Facebook, business alliances). Thus, in intrafirm inventor networks, it is clear who is at risk of being connected—every inventor employed by the firm—yet most teams within a firm do not interact with each other. Traditional measures of brokerage and closure are less useful for such networks. As Fleming et al (2007) point out: “an important limitation of small-world measures is that the network must be fully connected (i.e., there must exist a path between any two nodes). Real social networks often include isolates.”¹¹ Fleming et al. (2007) further find that small-worldness is not associated with innovative output, while size of the giant component is strongly positively correlated with it. Similarly, (Guimera, Uzzi, Spiro & Amaral, 2005) find that teams publishing in journals with high-impact factors were organized within networks characterized by a large giant component, whereas teams publishing in low-impact journals were typically located in networks with many small isolated clusters. Innovation studies have increasingly focused on the role of the relative size of the giant component in sparking innovation (e.g., Kogut, Colomer & Belinky (2014); Moeen, Somaya & Mahoney (2013); Schilling (2015); Fleming et al. (2007)).

Consequently, our first measure of network structure is *Relative Giant Component Size*, measured as the proportion of a firm's inventors who are connected within the largest cluster within

¹⁰Network dynamics at the whole-network level (which here includes components at-risk of joining the main network) and at the node-centric ego-network level, though related, are distinct (Ahuja et al., 2012). In the node-centric approach, the unit of analysis is generally an individual inventor or firm (the node). Ego-network analysis in innovation research seeks to explain how a node's position and ties affect innovation outcomes. Thus, ego-network measures such as local clustering, centralization, and coreness capture averaged node properties, not properties such as the distribution of components (i.e., whole-network connectedness).

¹¹For example, one of these measures, the popular “small worlds” measure, captures both clustering and path length navigability in a network (e.g. Baum, Shipilov & Rowley (2003); Kogut & Walker (2001)). However, this construct is not very useful for our purposes because it is simply impossible to navigate between the very large numbers of disconnected components that we observe in our networks.

the firm’s co-invention network. Figure 2 visualizes the evolution of one of our intrafirm inventor networks using the *Gephi* software package Bastian, Heymann & Jacomy (2009). We can see the preponderance of isolated clusters, often consisting of just a handful of inventors, as well as very large giant clusters. The figure also shows how dramatically these networks can change in just a few years. Within our sample, the average number of “components” – that is, isolated, discrete co-invention networks within the firm – was 46.7, with a maximum of 1455.

[INSERT FIGURE 2 ABOUT HERE]

While these graphs are suggestive, visual representations of network structure are difficult to interpret in general, and simply impossible in our setting,¹² with 7,623 network maps. Therefore, for our empirical analysis we use formal measures. The relative giant component size ($Giant_{kt}$) is calculated as follows:

$$Giant_{kt} = \frac{NumInvLargestCluster_{kt}}{NumInvFirm_{kt}}$$

where $NumInvLargestCluster_{kt}$ represents the number of inventors in the largest cluster, or component, of firm k ’s network in year t , and $NumInvFirm_{kt}$ represents the total number of inventors at firm k in year t . The numerator and denominator are based on all patents for which firm k submits *applications* in year t , regardless of whether or when they were granted.

As a network’s nodes coalesce into larger connected clusters, the overall network structure becomes less random and disorganized, so that entropy (disorder) generally decreases. This is the logic behind *normalized entropy* (Borgatti & Cross, 2003), a complementary measure to Giant which is less frequently used in a management context, but which captures heterogeneity in the size of the network components.¹³ In general, a high value of entropy represents an evenness of component sizes, while a low value represents heterogeneity in component sizes. Formally,

¹²Schilling (2015) analyzed 16 network mappings, and used a simpler measure which calculated the ratio of nodes connected to the giant. This measure, however, does not capture the distribution of connections among non-giant components, which is important in our setting.

¹³for a detailed discussion of the virtues of normalized entropy as a measure for network cohesiveness see (Amburgey et al., 2008)

$Entropy_{kt}$ is a measure of the normalized entropy of the network:

$$H = - \sum_{c=1}^c [(N_c/N) * \log(N_c/N)]$$

where C is the number of components, and N_c is the number of nodes in component c . Since the maximum value that H can take is $\log C$, we can normalize its value between 0 and 1. *Normalized entropy* equals 1 when all components have the exact same size, and is calculated as:

$$Entropy_{kt} = H_{norm} = \frac{H}{\log C}$$

The more asymmetric the distribution of component sizes, the lower the entropy value. Figure 3 shows a simplified example of how the integration of formerly isolated clusters drives both a larger normalized giant (main) component, and lower entropy. In actual networks, each one measures related but different things: put simply, Giant tells us about the size of the main component relative to all other components, while Entropy tells us additional information about the distribution of sizes among the other components.

[INSERT FIGURE 3 ABOUT HERE]

Formal R&D structure

We construct the continuous variable $BudgetCentralization_{kt}$ as the cumulative change in the share of firm k 's R&D budget that is allocated to corporate headquarters in year t . This variable can take values $[-1,1]$. For example, a firm that goes from 100% centralized to 100% decentralized would have a value of -1, whereas a firm that moves from 100% decentralized to 100% centralized would take a value of 1. This allows us to capture the directionality of cumulative change, not only the extent of change. We include firm fixed effects in all of our estimations; hence the coefficient on $BudgetCentralization$ can be interpreted as the within-firm effect of changes in this share.¹⁴ For subsequent spline estimations we unpack whether any relationship between budget control

¹⁴We thank an anonymous reviewer for pointing out the advantage of a continuous measure of change.

and our dependent variables is driven by firms that are centralizing vs. decentralizing. We construct $DecreasedBudgetCentralization_{kt}$, which equals the value of $BudgetCentralization_{kt}$ for observations in which $BudgetCentralization_{kt} < 0$ (set to zero otherwise), and we construct $IncreasedBudgetCentralization_{kt}$ analogously for positive changes in centralization.

In alternative estimations, we also use a discrete measure of structural change. We constructed the categorical variable $Centralizer_k$, set equal to 1 if firm k ever substantially centralized its R&D budget during the observation period, and 0 otherwise. We constructed the categorical variable $Decentralizer_k$ analogously based on decentralization of R&D budget. We defined a substantial change as one that increases or decreases the corporate share of a firm's R&D by more than 40 percentage points, yielding seven centralizers and nine decentralizers.¹⁵ We also constructed the categorical variable $After_{kt}$, set equal to 0 until the year that firm k changed and 1 thereafter (or, if firm k is a non-changing peer firm, set equal to 0 until the year that the "changer" firm to which firm k is matched changed, and 1 thereafter). Finally, we constructed $Centralizer_k * After_{kt}$ and $Decentralizer_k * After_{kt}$ by interacting $Centralizer$ and $After$ or $Decentralizer$ and $After$, respectively.

As described in the next section, these interacted independent variables allow us to perform a set of estimations that shed further light on potential timing and mechanisms behind our main results. Once again, our interest is in the organizational mechanisms through which this choice has its affects (on innovation), not on the determinants of that initial choice. While econometrically this specification is the same as a typical differences-in-differences regression framework, the purpose of the interaction terms here is not to establish causality, but simply to demarcate the temporal windows before and after the change, in order to observe the patterns of ensuing change.

Breadth and impact of innovation

We focus on two widely accepted measures of innovative search and output. We measure the breadth of technological search as a function of the technology classes of the patents cited by

¹⁵The results are qualitatively similar for a range of cutoffs. No firm both substantially centralized and decentralized its R&D during the sample period.

patent j . Specifically, for each patent j we construct the variable $Originality_{jkt}$ (Hall & Ziedonis, 2001), calculated as one minus the Herfindahl index of the primary U.S. patent classes of the patents cited by patent j . Similarly, we measure the breadth of innovation impact by constructing the variable $Generality_{jkt}$, calculated as one minus the Herfindahl index of the primary U.S. patent classes of the patents that cite patent j (Hall, Jaffe & Trajtenberg, 2005). For firm-level estimations, we average $Originality_{jkt}$ across all patents by firm k in year t to construct $Originality_{kt}$. We construct $Generality_{kt}$ analogously.

Control variables

We include numerous control variables in our regressions. Firm size may influence the nature of innovation undertaken (Cohen & Klepper, 1996). We therefore include $LnSales_{kt}$, $LnAssets_{kt}$, and $LnEmployees_{kt}$, measured as the natural log of sales, assets, and employees, respectively, to control for such size effects. A firm's R&D expenditure is also likely to affect its innovative efforts. We therefore include $LnR\&D_{kt}$, measured as the natural log of R&D expenditure. Other aspects of a firm's research effort may affect the breadth of search or impact. We include $PatentCount_{kt}$, which captures the number of ultimately successful patents that firm k applied for in year t . $RatioInternalToExternalPatents_{kt}$ reports the share of patents generated by the firm relative to its overall patent stock, thus controlling for firms that are more likely to buy their technology, and for whom internal spillovers may be less relevant to achieving innovative goals. $NonPatentReferences_{jkt}$, measured as a count of the references to non-patent literature (i.e., scientific publications) made by patent j , controls for the "basicness" of patent j 's underlying research; for firm-level estimations we construct $AvgNonPatentReferences_{kt}$ by averaging $NonPatentReferences_{jkt}$ across all of firm k 's patents in year t .

$PatentFamilySize_{jkt}$, measured as a count of the patents in the patent family to which patent j belongs, controls for instances in which multiple patents cover aspects of the same invention (Martínez, 2011), and which can distort citation counts; for firm-level estimations we construct $AvgPatentFamilySize_{kt}$. The manner in which we measure breadth of innovation

impact may be affected by the sheer number of citations that a patent receives. We control for this by including $5YrForwardCitations_{jkt}$, measured as the count of citations that patent j receives in the five years after its application; and $Avg5YrForwardCitations_{kt}$ for firm-level estimations. In estimations of network properties, we also control for the size of the network via $NumComponents_{kt}$, measured as the number of separate components in the co-invention network. Finally, in patent-level regressions we include firm, technology class, and year fixed effects, and in firm-level regressions we include firm and year fixed effects (firms rarely change primary NAICS, so we do not include industry fixed effects). The firm-level control variables are derived from COMPUSTAT and the patent-level control variables are derived from PATSTAT.

To give a sense of the raw data, Figure 4 shows the change in network structure for one of our pharmaceutical firms, which sharply increased its level of R&D centralization in 1997.¹⁶ A plot of the firm's annual co-invention network measures *Giant* and *Entropy*, relative to the average of other firms in the same four-digit primary NAICS class, shows some suggestive patterns. First, we see a strong secular trend towards larger giant component and lower entropy over time for *all* firms. Such trends underscore the importance of using an industry comparison set rather than simply examining the mean effect for firms that change their degree of centralization. Of particular note, the slope of the changer's trend line, which had been very similar to the peer firms prior to 1997, demonstrates a stark shift relative to its peers after centralization.

[INSERT FIGURE 4 HERE]

ESTIMATION RESULTS

As discussed earlier, we do not seek to establish causality through our estimations, but rather to document a set of conditional correlations that have not been explored in the literature and to assess whether they are consistent with our hypotheses. The goal is to inform both theory development and future empirical work. We employ two empirical strategies to do this. First, we estimate a set of models that explore the dyadic relationships between our constructs of interest and perform a set of mediation analyses to tease out the proportion of direct and indirect effects for their joint estimation. Second, we explore the rate at which co-invention networks and innovative

¹⁶Confidentiality agreements prevent us from disclosing identifying information on our firms.

outcomes change after the formal shift in budget authority. This allows us to document, for the first time to our knowledge, the temporal dimension of organizational and innovative change for a representative panel of firms.

Empirical strategy 1: conditional correlations and mediation tests

We estimate a battery of ordinary least-squares regressions of the form:

$$Outcome_{kt} = \alpha + \beta_1 BudgetCentralization_{kt-1} + \gamma X_{kt-1} + \theta Z_{kt-1} + \delta Firm_k + \omega Year_t + \epsilon_{kt} \quad (1)$$

and

$$Outcome_{kt} = \alpha + \beta_2 Networkmeasure_{kt-1} + \gamma X_{kt-1} + \theta Z_{kt-1} + \delta Firm_k + \omega Year_t + \epsilon_{kt} \quad (2)$$

where *Outcome* is each of the above-described outcomes of interest for firm k in year t . Our independent variable in specification (1), *BudgetCentralization* is the above-defined calculation of cumulative R&D budget centralization, and for (2) *Networkmeasure* is either *Giant* or *Entropy*; X is a vector of time-varying firm-specific covariates; Z is a vector of patent-specific covariates averaged across firm k 's patents in year t ; and *Firm* and *Year* are fixed effects. The coefficient of interest in Equation (1) is β_1 , which reflects the change in co-invention network or innovative outcome after an R&D structure change.¹⁷ In the spline estimations we replace $\beta_1 BudgetCentralization$ with $\beta_2 IncreasedBudgetCentralization$ and $\beta_3 DecreasedBudgetCentralization$. The coefficient of interest in Equation (2) is β_2 , which reflects the change in innovative outcome as a function of co-invention network characteristics. For all regressions, standard errors are clustered at the firm level to allow for autocorrelation of the error term within firms and across years. We then conduct a multilevel mediation analysis.

Hypothesis 1 proposes that centralizing R&D is associated with an increase in the connectedness of the firm's intrafirm inventor networks, and vice versa for decentralization. Because *Giant* increases with connectedness and *Entropy* decreases, we thus expect that the coefficient

¹⁷When the dependent variable is measured at the level of the patent rather than the firm-year, we replace $Outcome_{kt}$ with $Outcome_{jkt}$ and Z_{kt-1} with Z_{jkt-1} . These estimations are available upon request.

on *BudgetCentralization* will be positive when *Giant* is the dependent variable and negative when *Entropy* is the dependent variable.

Table 1 presents results of estimations. Consistent with our hypothesis, Models 1 and 2 show that a one-unit increase *BudgetCentralization* – that is, a change from pure decentralization to pure centralization – is indeed associated with an increase in *Giant* of about 33% (0.18, $p < 0.01$) and with a 29% decrease in *Entropy* ($-0.096, p < 0.01$). In unreported specifications (which we discuss in the robustness section) we find that modest changes also show these correlations, so the effect appears to not be limited to firms that change dramatically. To get a sense of scale, a more modest one-standard deviation increase in centralization would be associated with a 1/6 standard deviation increase in *Giant* and a 1/7 standard deviation decrease in *Entropy*. Models 3 and 4 present results from 2-spline estimations, in which we separately regress the independent variables for those that centralized and for those that decentralized. We find that the coefficients on *IncreasedBudgetCentralization* exhibit the same pattern as those on the blended *BudgetCentralization* variable, but with considerably larger point estimates, suggesting an increase of approximately 48% in *Giant* size for a one-unit increase in centralization (and a commensurate decrease in *Entropy*). Here, a one-standard deviation increase in centralization would be associated with a 1/4 standard deviation increase in *Giant*. Surprisingly, while the coefficients on *DecreasedBudgetCentralization* exhibit the predicted (opposite) sign, they are substantially smaller in absolute magnitude than those on *IncreasedBudgetCentralization*, and are not meaningful at conventional levels of statistical significance. Thus, although we find evidence consistent with Hypothesis 1, the relationship between R&D budget changes and network changes appears to be driven primarily by increases in centralization. However, we must exercise caution in interpreting these non-results, which call for future study. We address potential interpretations of this unexpected finding below.

[INSERT TABLE 1 ABOUT HERE]

Next, we turn to Hypotheses 2a and 2b, which predict that inventor network connectedness is positively associated with breadth of innovative impact and of innovative search. Models 1 and

2 in Table 2 present results of estimations that regress *Originality* and *Generality* on *Giant*, while Models 3 and 4 regress them on *Entropy*. We find that *Giant* is positively associated both with *Originality* (0.074; $p < 0.01$) and *Generality* (0.081; $p < 0.01$), which corresponds to approximately a 4% increase in both for a one-standard deviation increase in *Giant*. Similarly, *Entropy* is negatively associated with *Originality* (-0.084 ; $p < 0.01$) and *Generality* (-0.1 ; $p < 0.01$) with slightly larger point estimates. Thus, consistent with Hypotheses 2a and 2b, a more connected network is associated with broader innovative search and broader innovative impact.

[INSERT TABLE 2 ABOUT HERE]

The above conditional correlations are consistent with our hypothesis that centralizing budgets will lead to more connected networks, and also that more connected networks are associated with broader and more innovative patents. However, as we have been discussing, it is not clear to what extent the formal centralization of R&D might impact innovation directly (through incentives, for example) versus indirectly (through the internal knowledge networks). To explore this further, we first quantify a magnitude for the correlation between centralization of R&D and any increases in breadth of innovative search and impact.

Table 3 presents results of corresponding estimations regressing innovative outcomes on *Budget Centralization*. Models 1 and 2 show that the coefficient on *BudgetCentralization* is positive for both innovative search as measured by *Originality* (0.063, $p < 0.057$) and innovative impact as measured by *Generality* (0.088, $p < 0.009$), which corresponds to increases of approximately 8.5% and 17.8% respectively for a one-unit change in centralization. Models 3 and 4 present results from spline estimations. Once again, the coefficients on *IncreasedBudgetCentralization* exhibit the same pattern as those on *BudgetCentralization*, with even larger magnitudes. In contrast, the coefficients on *DecreasedBudgetCentralization* are not statistically significant and quite smaller in magnitude. The effect of R&D budget changes on innovation outcomes thus also appears to be largely associated with increases in centralization.¹⁸

[INSERT TABLE 3 ABOUT HERE]

¹⁸This finding suggests that there is directionality to the dynamics of network change. We discuss this in our concluding section.

Having established these three dyadic relationships between R&D structural change, network change, and innovative outputs, we explore how the relationship between budget structure and outputs may be mediated by the evolution of the firm's co-invention network. To do this, we perform multilevel modeling mediation analyses, using the `ml_mediate` package developed by UCLA's Institute for Digital Research and Education (IDRE). This set of routines implement the methodology of Krull & MacKinnon (2001) to overcome the challenge of appropriately analyzing clustered data, preserving the original data structure (in our case allowing the use of firm and year fixed effects) while explicitly modeling the within-group homogeneity of errors with both individual and group errors. Given the nature of the error terms, iterative Empirical Bayes/maximum likelihood (EB/ML) is used, and standard errors were bootstrapped with 5000 replications. Figure 5 illustrates the mediating effect of our network topology measures on the relationship between budget centralization and patent outcomes.

[INSERT FIGURE 5 AND TABLE 4 ABOUT HERE]

As Panel A of Table 4 reports, we find that Giant mediates roughly 13% of the total change in Originality and 18% of the total change in Generality for firms that centralize their R&D. For Entropy, the mediation is approximately 16% and 13% respectively. Given the large standard errors in our earlier regressions looking at the relationship between decentralization and patent measures, it is not surprising that the mediation results are not very significant for decentralization. Nonetheless, in terms of magnitude, the coefficients are broadly similar, as reported on Panel B on Table 4. Thus, while the shift in formal R&D budget authority may change inventors' incentives to make them more willing to pursue broader innovation, a non-trivial part of their ability to do this appears to depend on the evolution of their co-invention networks.

Empirical strategy 2: speed of change in co-invention networks and outcomes

Our second empirical approach explores the rate at which co-invention networks and innovative outcomes change after a formal shift in budgetary authority. This is useful for a number of reasons. Cross-sectional network analysis has considerable limitations, because relationships are

inherently ambiguous (Brass, Galaskiewicz, Greve & Tsai, 2004). Thus, despite not having exogenous variation in order to establish proper causality, we can still observe the temporal ordering of these changes and document whether, for example, networks or innovation change first. For this analysis to be tractable, we must identify the specific year in which a change occurs. We therefore rely on the categorical measures of *Centralizer* and *Decentralizer* described in our Data section. We estimate ordinary least-squares regressions of the form:

$$Outcome_{kt} = \alpha + \beta_3 Changer_k + \beta_4 After_t + \beta_5 Changer_k * After_t + \gamma X_{kt-1} + \theta Z_{kt-1} + \sigma Firm_k + \omega Year_t + \epsilon_{kt} \quad (3)$$

where *Changer* indicates *Centralizer* in estimations of the centralization-outcome relationship, and indicates *Decentralizer* in estimations of the decentralization-outcome relationship.

In these models, the key coefficient of interest is β_5 , which reflects the change in innovative outcome after the time of R&D structure change for those firms that change, as compared to their non-changing matched peers. Although these estimations do not provide statistical evidence of mediation, they provide compelling circumstantial evidence. If, for example, the speed of change in innovative outcomes is similar to that of co-invention networks, this would be consistent with the proposed network-based mechanism, insofar as these ought to evolve together. Alternatively, if we were to find that (for example) innovative outcomes change before the network does, this would argue against the hypothesis that networks are involved in driving the change in innovation. Needless to say, if either of these changed before the budget change, then we would worry that budget change itself might be an outcome of change in networks or innovation.

We begin with Table 5, which replicates the estimations from Table 2 using our discrete measures for budgetary change to confirm that we get similar baseline results. We ran the models separately for centralizing firms (vs. non-changing firms) and for decentralizing firms (vs. non-changing firms), given the different effects implied in Table 2. Models 1 and 2 present results for centralizing firms. Consistent with Hypothesis 1 and with Table 2, the coefficient on *Centralizer*After* is positive when *Giant* is the dependent variable (0.25; $p < 0.01$) and negative

when *Entropy* is the dependent variable ($-0.15; p < 0.01$). Models 3 and 4 present results for decentralizing firms; consistent with Table 2, the coefficients on *Decentralizer * After* are far smaller in absolute magnitude, and are effectively zero given the large standard errors. The results using categorical variables indicate that substantial changes to R&D budgetary authority are qualitatively similar to those using a continuous measure of budgetary change.

[INSERT TABLE 5 ABOUT HERE]

To investigate the speed with which network connectedness and innovative breadth change after a shift in formal structure, Table 6 divides the “after” period into annual spells. Models 1 and 2 present results for centralizing firms.¹⁹ These models indicate that the impact of increased centralization of formal R&D budget authority on inventor network structure occurs with a lag: although the coefficients on *Giant* and *Entropy* suggest a modest impact in the year following the change, this effect increases (in absolute value and statistical significance) over the subsequent several years, reaching conventional levels of statistical significance around year 3, where we see *Giant* increasing by approximately 28% and *Entropy* decreasing by approximately 13%. Thus a sharp increase in centralization of R&D budgetary authority is associated with a gradual change in the co-invention network within a firm. Models 3 and 4 present the results of analogous estimations for which breadth of innovation is the dependent variable. These models indicate a similar lag in impact of centralization; the coefficients on *Originality* and *Generality* both show an increase that is almost monotonic for several years following the shift, reaching conventional levels of statistical significance around year 3 or 4. For both network and innovation measures, we see a plateauing of the effect after around 5 or 6 years; this can be best visualized in Figure 6, which plots the coefficients for all four models.

[INSERT FIGURE 6 ABOUT HERE]

Although there is no statistical test to explore these patterns, they shed intuitive light on the role of network evolution as a mechanism. If formal structural changes were associated with discrete changes to innovation outcomes, then this would suggest that merely changing

¹⁹Because results for decentralizing firms show little evidence of a relationship with networks or the innovative outcomes above, we do not report results for them at the annual-spell level.

the authority and incentives for innovation is sufficient to alter innovative effort. However, the fact that changes to innovative breadth occur gradually and in tandem with evolution of the co-invention network suggests that these outcomes depend on the rearrangement of inventor networks, consistent with theories that emphasize the role of slow changes in more “informal” structures within the firm (Nickerson & Zenger, 2002). Thus, inventors willing to pursue broader innovation after the firm’s formal structure is changed may have to wait until the informal network changes. Of course, many contingencies may influence the potential co-evolution of innovation networks and patenting, but the patterns we show are nonetheless consistent with the “coherence” view (Nadler, Tushman & Nadler, 1997; Siggelkow, 2011; Teece, Rumelt, Dosi & Winter, 1994), which is less interested in linear causality, and emphasizes the importance of complementary organizational elements.

[INSERT TABLE 6 ABOUT HERE]

Robustness checks and additional analyses

We conducted several robustness checks that are available upon request. First, it is possible that a focus on firm-level averages obscures the underlying relationship between R&D structure and innovation, which presumably plays out in individual research projects. We therefore re-estimated all models with the unit of observation being the patent, and find stronger support for our hypotheses. Second, we re-estimated all models using SIC rather than NAICS as a basis for identifying control firms. Third, we re-estimated all models using only the 96 firms that appear in CIMS/IRI (these results appear in the online appendix). Fourth, we re-estimated the models that relied on a categorical measure of substantial change to R&D structure using different thresholds for a substantial change. Fifth, we re-estimated all models using synthetic matching of control firms for the subset of firms for which we could construct a balanced panel. Sixth, we re-estimated the annual-spell models using networks that included, rather than excluded, inventors hired after the substantial change in R&D structure. Seventh, we re-estimated all models using a two-year lag instead of a one-year lag in innovative outcome. Eighth, we re-estimated all models after

excluding those firms with dramatic changes in R&D centralization (i.e., those with changes of more than 40 percentage points). All of these checks yielded results that were qualitatively similar to those reported above.

DISCUSSION AND CONCLUSION

Prior research on R&D organization structure has been limited to documenting static associations between R&D organizational form and innovation outcomes. This is not surprising given the dual challenge of observing both structure and change (Gavetti et al., 2007). Our paper proposes an important mechanism underlying this relationship: intra-firm inventor networks. We find that the relationship between changes in formal R&D organization structure and changes in firms' innovative outcomes manifests itself at least partly through changes in the connectedness of inventor networks. Specifically, centralization of R&D budget authority is associated with greater subsequent connectedness of the intra-firm co-invention network, which in turn is associated with innovations exhibiting broader search and impact. The full effect of increased centralization of R&D on both co-invention networks and innovation occurs with a lag of 3+ years, as network connectedness and innovative breadth gradually increase in tandem. The considerable lag between budget intervention and observable new collaborations makes it unlikely that the collaborations are driven by authoritarian fiat making inventors work together, as it would be unlikely that a R&D manager tasked with connecting inventors would be allowed to let several years pass before any of their subordinates actually connected.

An implication of our findings is that social network structure responds to changes in formal organization structure made by organizational designers. Recent research on organizational network dynamics emphasizes that network change occurs as agents in the network (nodes) respond to incentives, opportunities and inertia by forming and deleting ties (Ahuja et al., 2012; Schilling, 2015). Our results contribute to this nascent framework by suggesting that changes in organizational design, by changing such agents' incentives and opportunities and relieving inertia, can spur changes in network structure. The corresponding managerial implication is that managers can and do influence the structure of their internal inventor network through changes in formal

R&D structure, and in so doing influence the impact of their firm's R&D activity (albeit with a multiyear lag). Our results also suggest that innovative outcomes are responsive to even modest changes to budgetary authority. Thus, managers need not make drastic changes to R&D structure in order to see associated changes in innovation.

Although we do not establish causality, we nonetheless contribute in salient ways. We document concurrent patterns of change in structure and innovation for a sample of firms that is nearly representative of all major patenting firms during the period 1986-2007. Empirical studies of network dynamics has been sparse (Ahuja et al., 2012), and with a strong focus on inter-firm networks. To our knowledge, a large-scale and multi-dimensional investigation of intra-firm networks such as ours has not been undertaken, and our results should stimulate future theoretical and empirical work on the dynamics of structure and innovation.

A surprising finding of our study was the lack of support for our hypotheses for the subsample of decentralizing firms. This raises an interesting question for future research: Why might directionality matter in the relationship between formal structure and internal networks? Underlying the very notion of social structure is the belief in some degree of durability (Coleman, 1988; Giddens, 1984). Networks are thought to have "memory" (Soda, Usai & Zaheer, 2004); so at one level it is not surprising that some characteristics of a network are resistant to change. However, the finding that this resistance is observed with directionality suggests some organizational hysteresis effects may be involved (Rios, Rachinskii & Cross, 2017). Future work might consider several possibilities. For example, when firms centralize R&D structure, two things occur: (a) there is disruption to the existing network of inventor ties, and (b) new boundary-spanning ties are mandated or encouraged. Both of these effects amplify innovative breadth; disruption leads to the formation of new ties, while extant ties presumably erode only slowly, and the push for boundary-spanning ties leads to the broad sharing of knowledge. In contrast, when firms decentralize their R&D structures, they experience the same reshuffling of ties, but the newly mandated/encouraged ties may be more proximate in technology or product space. This narrowing of ties may lead to a narrowing of innovation, but because the disruptive effect works slowly

it reduces the strength of the narrowing effect of decentralization. This mixing of formal and informal changes is consistent with Nickerson & Zenger (2002)'s concept of vacillation in formal structures to exploit slower-moving informal organization.

Future work might also quantify how much of the impact of R&D centralization/decentralization on intrafirm networks occurs through the mechanism of geographic relocation of researchers. Our study controlled for this using data detailing the closing, relocation, or opening of labs. However, it would be interesting to further explore whether additional effects of changes in R&D authority on network cohesiveness may occur as a result of reassigning divisional researchers to a centralized R&D lab in a different geographic location. A decision to decentralize budget authority, on the other hand, may involve asking a number of researchers in a centralized lab to move to divisional labs that are in a different location. These locational changes will expose the reassigned researcher to a different set of proximate colleagues, and hence the knowledge these colleagues possess. This will in turn affect their patent citation behavior; physical proximity has repeatedly been found to affect patent citation choices (Agrawal et al., 2008; Singh & Mitchell, 2005; Singh & Marx, 2013). Our assumption is that moving to a centralized lab will expose a researcher to a broader base of knowledge than that which is available at a divisional lab. However, we note that some of the new collaborations induced by a change in R&D structure may be initiated between researchers who remain in their original locations and collaborate remotely. More research on the intra-firm geography of innovation is needed.

Finally, a potentially fruitful area for research is to examine the impact of changes in a firm's R&D organizational structure on the nature and extent of its external collaborations. It has been shown that firms with centralized R&D, for example, tend to rely less on acquiring innovation through acquisitions (Arora et al., 2014). Moreover, when firms with centralized R&D do seek external innovation, they are more likely to make acquisitions whose R&D is absorbed into their own. It would be interesting to test whether these relationships involving acquisitions and absorption persist in longitudinal data, and whether one can observe whether R&D centralization leads to more cohesive networks of inventors working across organizational boundaries between

firms and universities, research institutes, government labs, and the like, and vice versa for R&D decentralization.

From a normative perspective, it is important to note that broader search and impact *per se* need not be “better.” As emphasized by Arora et al. (2014) a firm’s emphasis on broader (narrower) innovation should be part of a coherent strategy that takes into account external technology and the market segments sought. Put simply, not all firms would benefit from broader or impactful technology, but for those that might organization could be considered as a lever to guide the direction of their research.

Organizational scholars have long been interested in the relationship between formal organizational structure and firm performance, and how changes in formal structure operate to influence firm performance. The absence of systematic data, however, has made empirical investigations of such relationships difficult. We hope that our own study will encourage more efforts to uncover the necessary data for exploring this important topic.

REFERENCES

- Abadie, A., Drukker, D. M., Herr, J. L., & Imbens, G. W. (2001). Implementing Matching Estimators for Average Treatment Effects in Stata. *The Stata Journal*, 1(1), 1–18.
- Agrawal, A., Kapur, D., & McHale, J. (2008). How do spatial and social proximity influence knowledge flows? Evidence from patent data. *Journal of Urban Economics*, 64(2), 258–269.
- Ahuja, G., Soda, G., & Zaheer, A. (2012). Introduction to the Special Issue: The Genesis and Dynamics of Organizational Networks. *Organization Science*, 23(2), 434–448.
- Amburgey, T. L., Al-Laham, A., Tzabbar, D., & Aharonson, B. (2008). The structural evolution of multiplex organizational networks: research and commerce in biotechnology. In J. A. Baum & T. J. Rowley (Eds.), *Network Strategy* chapter 25, (pp. 171–209). Emerald Group Publishing Limited.
- Argyres, N. S. (1996). Capabilities, Technological Diversification and Divisionalization. *Strategic Management Journal*, 17(5), 395–410.
- Argyres, N. S. & Silverman, B. S. (2004). R&D, organization structure, and the development of corporate technological knowledge. *Strategic Management Journal*, 25(89), 929–958.
- Arora, A., Belenzon, S., & Rios, L. (2014). Make, buy, organize: The interplay between research, external knowledge, and firm structure. *Strategic Management Journal*, 35(3), 317–337.
- Arts, S., Cassiman, B., & Gomez, J. C. (2018). Text matching to measure patent similarity. *Strategic Management Journal*, 39(1), 62–84.
- Bastian, M., Heymann, S., & Jacomy, M. (2009). Gephi: An Open Source Software for Exploring and Manipulating Networks. *Proceedings of the Third International ICWSM Conference*, 361–362.
- Baum, J. A. C., Shipilov, A. V., & Rowley, T. J. (2003). Where do small worlds come from? *Industrial and Corporate Change*, 12(4), 697–725.
- Birr, K., Hounshell, D. A., & Smith, J. K. (2006). Science and Corporate Strategy: Du Pont and R&D, 1902-1980. *Technology and Culture*, 31(2), 338.
- Borgatti, S. P. & Cross, R. (2003). A relational view of information seeking and learning in social networks. *Management Science*, 49(4), 432–445.
- Brass, D. J., Galaskiewicz, J., Greve, H. R., & Tsai, W. (2004). Taking Stock of Networks and Organizations: A Multilevel Perspective. *Academy of Management Journal*, 47(6), 795–817.
- Burt, R. (2004). Structural Holes and Good Ideas. *American Journal of Sociology*, 110(2), 349–399.
- Cohen, W. & Klepper, S. (1996). A reprise of size and R & D. *The Economic Journal*, 106(437), 925–951.

- Coleman, J. S. (1988). Social Capital in the Creation of Human Capital. *American Journal of Sociology*, 94(1), s95–s120.
- Csárdi, G. & Nepusz, T. (2014). The igraph software package for complex network research. *Journal of Computer Applications*, 9.
- Fleming, L., King, C., & Juda, A. I. (2007). Small Worlds and Regional Innovation. *Organization Science*, 18(6), 938–954.
- Fleming, L., Mingo, S., & Chen, D. (2007). Collaborative brokerage, generative creativity, and creative success. *Administrative Science Quarterly*, 52(3), 443–475.
- Fleming, L. & Sorenson, O. (2004). Science as a map in technological search. *Strategic Management Journal*, 25(8-9), 909–928.
- Gans, J. S., Hsu, D. H., & Stern, S. (2008). The impact of uncertain intellectual property rights on the market for ideas: Evidence from patent grant delays. *Management Science*, 54(5).
- Gavetti, G., Levinthal, D. A., & Ocasio, W. (2007). Perspective—Neo-Carnegie: The Carnegie school's past, present, and reconstructing for the future. *Organization Science*, 18(3), 523–536.
- Giddens, A. (1984). *The Constitution of Society*. Number 26. Berkeley and Los Angeles: University of California Press.
- Grigoriou, K. & Rothaermel, F. T. (2017). Organizing for knowledge generation: Internal knowledge networks and the contingent effect of external knowledge sourcing. *Strategic Management Journal*, 38(5), 961–964.
- Guimera, R., Uzzi, B., Spiro, J., & Amaral, L. A. N. (2005). Team assembly mechanisms determine collaboration network structure and team performance. *Science*, 308(5722), 697–702.
- Guler, I. & Nerkar, A. (2012). The impact of global and local cohesion on innovation in the pharmaceutical industry. *Strategic Management Journal*, 33(August), 535–549.
- Hall, B. H., Jaffe, A. B., & Trajtenberg, M. (2005). Market value and patent citations. *RAND Journal of Economics*, 36(1), 16–38.
- Hall, B. H. & Ziedonis, R. H. (2001). The patent paradox revisited: an empirical study of patenting in the U.S. semiconductor industry, 1979-1995. *The RAND Journal of Economics*, 32(1), 101–128.
- Hansen, M. T. (1999). The search-transfer problem: The role of weak ties in sharing knowledge across organization subunits. *Administrative Science Quarterly*, 44(1), 82–111.
- Harhoff, D. & Wagner, S. (2009). The duration of patent examination at the European Patent Office. *Management Science*, 55(12), 1969–1984.
- Henderson, R. M. & Clark, K. B. (1990). Architectural innovation: The reconfiguration of existing product technologies and the failure of established firms. *Administrative Science Quarterly*, 35(1), 9–30.

- Holmstrom, B. & Milgrom, P. (1994). The firm as an incentive system. *The American Economic Review*, 84(4), 972–991.
- Hoskisson, R. E., Hitt, M. A., & Hill, C. W. L. (1993). Managerial incentives and investment in R&D kkin large multiproduct firms. *Organization Science*, 4(2), 325–341.
- Jensen, M. C. & Meckling, W. H. (1992). Specific and General Knowledge and Organizational Structure. In L. Werin & H. Wijkander (Eds.), *Contract Economics* (pp. 251–274). Oxford: Blackwell Publishing.
- Karim, S. & Kaul, A. (2015). Structural Recombination and Innovation: Unlocking Intra-organizational Knowledge Synergy Through Structural Change. *Organization Science*, 26(2), 439–455.
- Katz, R. & Allen, T. J. (1982). Investigating the Not Invented Here (NIH) syndrome: A look at the performance, tenure, and communication patterns of 50 R&D Project Groups. *R&D Management*, 12(1), 7–20.
- Kay, N. (1988). The R\&D function: corporate strategy and structure. In G. Dosi, C. Freeman, R. Nelson, G. Silverberg, & C. Soete (Eds.), *Technical Change and Economic Theory* (pp. 282–294). Pinter: London.
- Koestler, A. (1964). *The act of creation*. London Hutchinson.
- Kogut, B., Colomer, J., & Belinky, M. (2014). Structural equality at the top of the corporation: Mandated quotas for women directors. *Strategic Management Journal*, 35, 891–902.
- Kogut, B. & Walker, G. (2001). The Small World of Germany and the Durability of National Networks. *American Sociological Review*, 66(3), 317–335.
- Krull, J. L. & MacKinnon, D. P. (2001). Testing predictive developmental hypotheses. *Multivariate Behavioral Research*, 36(2), 227–248.
- Leiponen, A. & Helfat, C. E. (2010). Location, Decentralization, and Knowledge Sources for Innovation. *Organization Science*, 22(3), 641–644.
- Martínez, C. (2011). Patent families: When do different definitions really matter? *Scientometrics*, 86(1), 39–63.
- McEvily, B., Soda, G., & Tortoriello, M. (2014). More Formally: Rediscovering the Missing Link between Formal Organization and Informal Social Structure. *Academy of Management Annals*, 8(1), 299–345.
- Moen, M., Somaya, D., & Mahoney, J. T. (2013). Supply portfolio concentration in outsourced knowledge-based services. *Organization Science*, 24(1).
- Moreira, S., Markus, A., & Laursen, K. (2018). Knowledge diversity and coordination: The effect of intrafirm inventor task networks on absorbtion speed. *Strategic Management Journal*, 39(9), 2517–2546.

- Nadler, D., Tushman, M., & Nadler, M. B. (1997). *Competing by design: The power of organizational architecture* (illustrate ed.). Oxford University Press, USA.
- Nahapiet, J. & Ghoshal, S. (1998). Social Capital , Intellectual Capital , and the Organizational Advantage. *Academy of Management Review*, 23(2), 242–266.
- Nelson, R. R. & Winter, S. G. (1982). *An evolutionary theory of economic change*. The Belknap Press of Harvard University Press.
- Nerkar, A. & Paruchuri, S. (2005). Evolution of R\&D capabilities: The role of knowledge networks within a firm. *Management Science*, 51(5), 771–785.
- Nickerson, J. A. & Zenger, T. R. (2002). Being efficiently fickle: A dynamic theory of organizational choice. *Organization Science*, 13(5), 547–566.
- Obstfeld, D. (2005). Social networks, the tertius iungens orientation, and involvement in innovation. *Administrative Science Quarterly*, 50(1), 100–130.
- Reagans, R. & Zuckerman, E. W. (2001). Networks, diversity, and productivity: The social capital of corporate R\&D teams. *Organization Science*, 12(4), 502–517.
- Rios, L., Rachinskii, D., & Cross, R. (2017). A model of hysteresis arising from social interaction within a firm. In *Journal of Physics: Conference Series*, volume 811, (pp. 1–12).
- Rios, L. A. (2019). On the origin of technological acquisition strategy: The interaction between organizational plasticity and environmental munificence. *Working Paper*.
- Rodan, S. & Galunic, C. (2004). More than network structure: How knowledge heterogeneity influences managerial performance and innovativeness. *Strategic Management Journal*, 25(6), 541–562.
- Schilling, M. A. (2015). Technology shocks, technological collaboration, and innovation outcomes. *Organization Science*, 26(3), 668–686.
- Schumpeter, J. A. (1942). The Process of Creative Destruction; Monopolistic Practices. In *Capitalism, Socialism and Democracy* (pp. 81–106). Routledge.
- Siggelkow, N. (2011). Firms as systems of interdependent choices. *Journal of Management Studies*, 48(5), 1126–1140.
- Simon, H. A. (1947). *Administrative Behavior: A Study of Decition-making processes in administrative organization*. MacMillan and Co. Limited.
- Singh, J. & Marx, M. (2013). Geographic constraints on knowledge spillovers: Political borders vs. spatial proximity. *Management Science*, 59(9), 2056–2078.
- Singh, K. & Mitchell, W. (2005). Growth dynamics: the bidirectional relationship between inter-firm collaboration and business sales in entrant and incumbent alliances. *Strategic Management Journal*, 26(6), 497–521.

- Soda, G., Usai, A., & Zaheer, A. (2004). Network Memory: the Influence of Past and Current Networks on Performance. *Academy of Management Journal*, 47(6), 893–906.
- Sorenson, O., Rivkin, J. W., & Fleming, L. (2006). Complexity, networks and knowledge flow. *Research Policy*, 35(7), 994–1017.
- Teece, D. J. (1996). Firm organization, industrial structure, and technological innovation. *Journal of Economic Behavior & Organization*, 31(2), 193–224.
- Teece, D. J., Rumelt, R., Dosi, G., & Winter, S. G. (1994). Understanding corporate coherence. *Journal of Economic Behavior & Organization*, 23(1), 1–30.
- Toh, P. (2014). Chicken, or the egg, or both? the interrelationship between a firm's inventor specialization and scop of technologies. *Strategic Management Journal*, 35.
- Tortoriello, M. & Krackhardt, D. (2010). Activating Cross-Boundary Knowledge : the Role of Simmelian Ties in the Generation of Innovations. *The Academy of Management Journal*, 53(1), 167–181.
- Uzzi, B. (1997). Social Structure and Competition in Interfirm Networks: The Paradox of Embeddedness. *Administrative Science Quarterly*, 42(1), 35.
- Wasserman, S. & Faust, K. (1994). *Social Network Analysis: Methods and Applications*. Cambridge MA: Cambridge University Press.
- Williamson, O. E. (1985). Transaction Cost Economics. In *The ECONOMIC INSTITUTIONS of CAPITALISM Firms, Markets, Relational Contracting* (pp. 15–38). The Free Press.
- Zander, U. & Kogut, B. (1995). Knowledge and the speed of the transfer and imitation of organizational capabilities: An empirical test. *Organization science*, 6(1), 76–92.

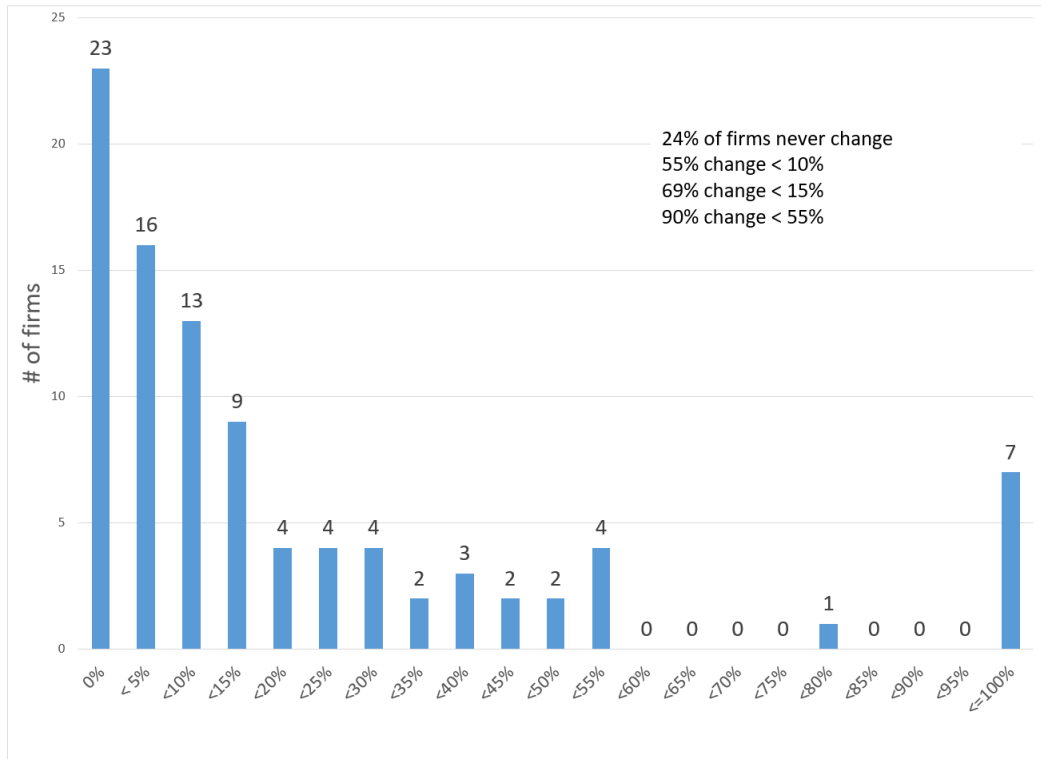

(a) Total change in share of corporate R&D during entire CIMS/IRI sample period

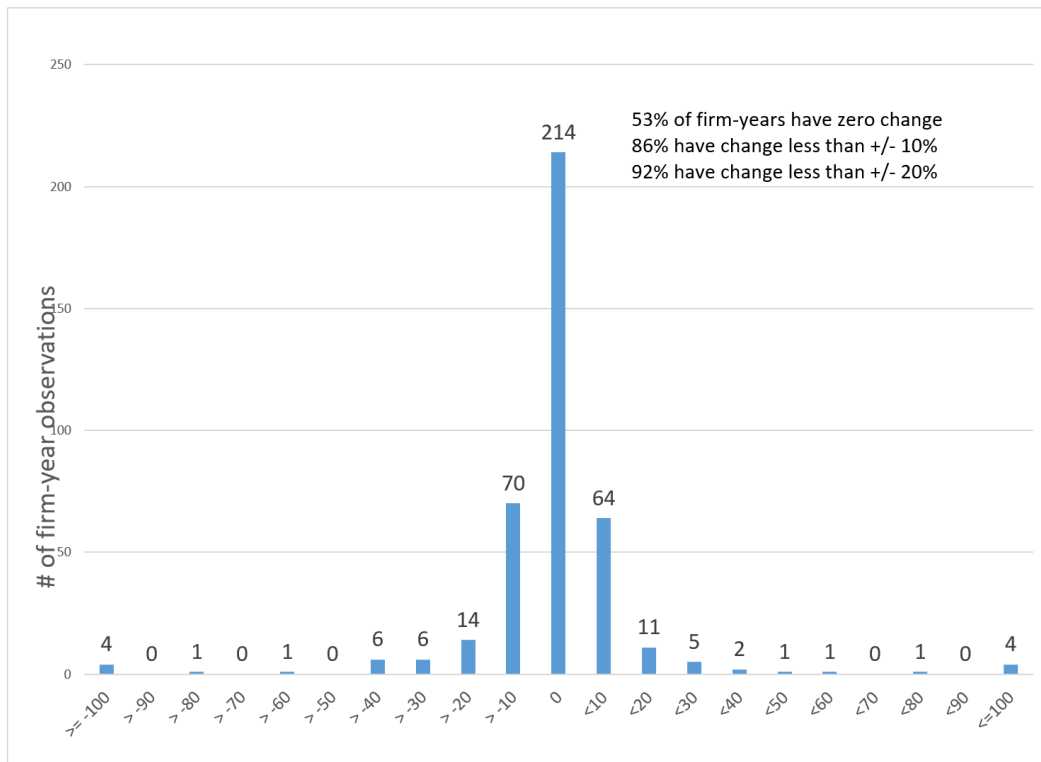

(b) Firm-year changes in budget centralization

Figure 1: Changes in centralization of budget for CIMS/IRI sample firms



Figure 2: Intrafirm co-patenting network for a firm that centralized R&D budget authority, 1 year before change on left and 3 years after on the right. While this is suggestive of a change in network topology, it also highlights the value of mathematical measures, because visual representations of whole-network structure are hard to interpret (Schilling, 2015).

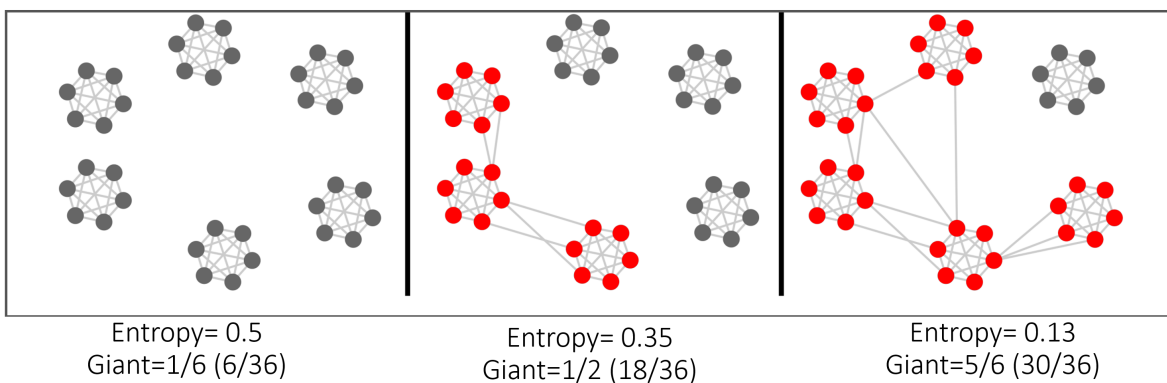

Figure 3: Stylized example of whole-network measures. As isolated components connect previously disconnected isolates, the relative giant component increases, while entropy decreases.

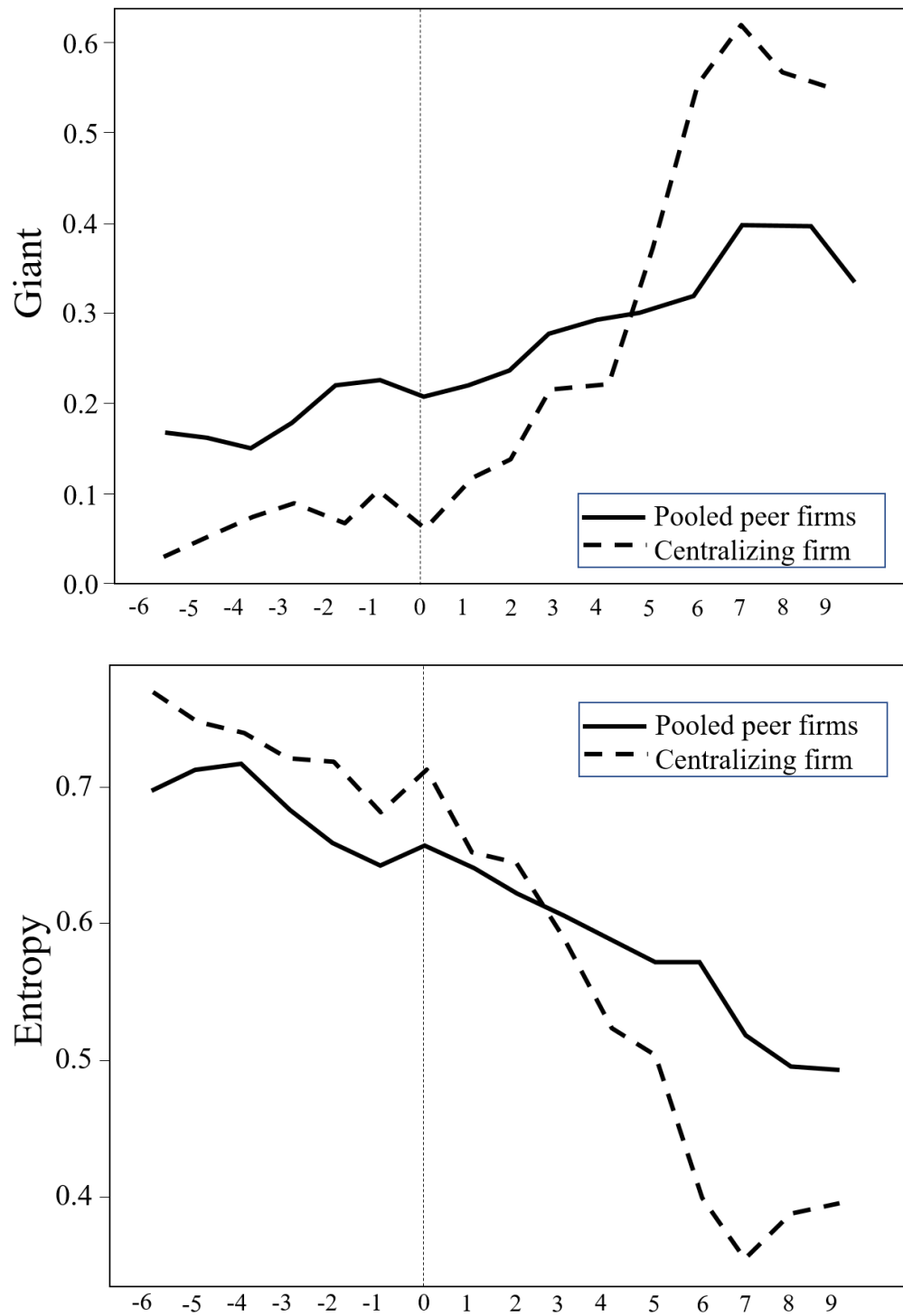

Figure 4: Changes in network giant component and normalized entropy: Centralizer firm vs. matched and pooled peer firms. X-axis labels show years pre and post-change

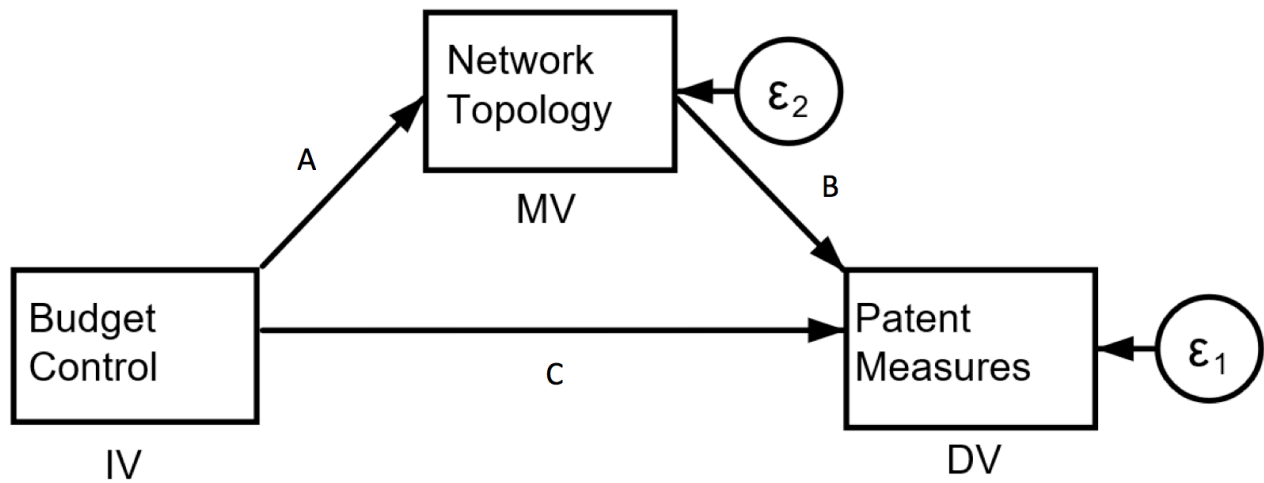

Figure 5: Mediation analysis. A Path: The independent variable (Budget Centralization) may influence the mediating variable (Normalized Entropy and Relative Giant Component size). B Path: The mediating variable similarly may influence the dependent variable (patent Originality and Generality). C Path: The IV may also have a direct impact on DV, independently of the mediated path. Results reported on Table 5.

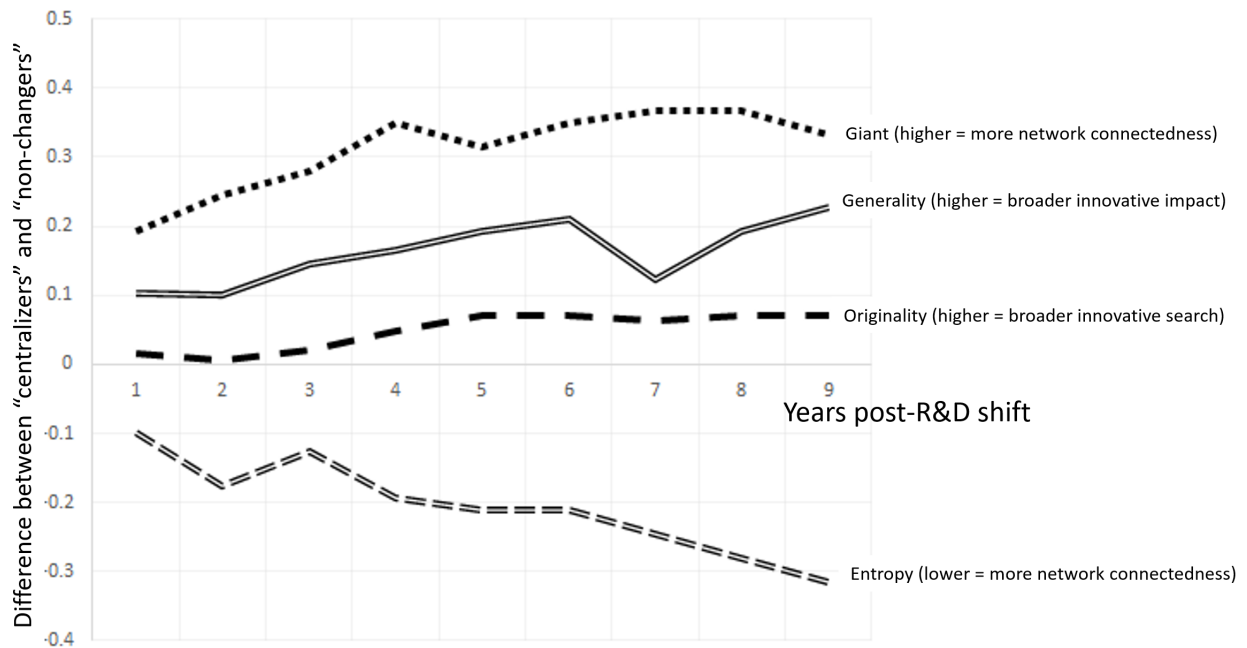

Figure 6: Plot of coefficients from Table 6. Years post-change on x-axis, coefficient point estimates on y-axis. We can see how both network and innovation measures trend gradually after centralization of R&D.

Table 1: Firm-level Structure Impact on Network

	(1)	(2)	(3)	(4)
	Giant	Entropy	Giant	Entropy
BudgetCentralization	0.18 (0.000)	-0.096 (0.002)		
IncreasedBudgetCentralization (0,1)			0.28 (0.000)	-0.16 (0.000)
DecreasedBudgetCentralization (0,-1)			-0.019 (0.890)	0.038 (0.661)
ln(Sales)	-0.0078 (0.447)	0.0057 (0.506)	-0.0072 (0.479)	0.0054 (0.534)
ln(Assets)	-0.0058 (0.688)	0.0046 (0.657)	-0.0067 (0.638)	0.0053 (0.611)
ln(Employees)	0.021 (0.336)	-0.018 (0.239)	0.022 (0.294)	-0.018 (0.204)
ln(R&D)	-0.020 (0.066)	0.012 (0.161)	-0.019 (0.085)	0.011 (0.194)
PatentCount	0.0026 (0.730)	-0.011 (0.050)	0.0038 (0.615)	-0.012 (0.036)
AvgNonPatentReferences	0.0057 (0.007)	-0.0043 (0.012)	0.0057 (0.007)	-0.0043 (0.013)
RatioInternaltoExternalPatents	0.0031 (0.881)	0.0011 (0.949)	0.0031 (0.881)	0.0011 (0.947)
Avg5-YrFwdCitations	0.001 (0.068)	-0.001 (0.031)	0.001 (0.062)	-0.001 (0.029)
AvgPatentFamilySize	0.0050 (0.598)	-0.0093 (0.186)	0.0048 (0.605)	-0.0092 (0.188)
NumComponents	-0.000 (0.583)	0.000 (0.209)	-0.000 (0.529)	0.000 (0.193)
Constant	0.49 (0.000)	0.48 (0.000)	0.49 (0.001)	0.45 (0.000)
Observations	6993	6993	6993	6993
R^2	0.69	0.73	0.69	0.73
Adjusted R^2	0.65	0.69	0.65	0.69
Year and Firm FE	Yes	Yes	Yes	Yes

Note: OLS Regressions. Unit of observation is firm-year. p-values reported in parentheses
Standard errors clustered at the firm level and robust to arbitrary heteroskedasticity.
All independent variables lagged by one year.

Table 2: Breadth of Search and Impact as a function of Network Structure

	(1)	(2)	(3)	(4)
	Originality	Generality	Originality	Generality
Giant			0.074 (0.004)	0.081 (0.002)
Entropy	-0.084 (0.002)	-0.11 (0.007)		
ln(Sales)	-0.0089 (0.221)	-0.0052 (0.688)	-0.0088 (0.225)	-0.0055 (0.672)
ln(Assets)	-0.018 (0.050)	-0.029 (0.062)	-0.018 (0.050)	-0.029 (0.062)
ln(Employees)	-0.00053 (0.968)	0.027 (0.259)	-0.00072 (0.957)	0.028 (0.245)
ln(R&D Expense)	0.013 (0.055)	0.0020 (0.890)	0.013 (0.053)	0.0016 (0.915)
PatentsCount	0.015 (0.006)	-0.0095 (0.325)	0.015 (0.007)	-0.0087 (0.363)
AvgNonPatentReferences	0.0046 (0.012)	0.010 (0.005)	0.0045 (0.013)	0.010 (0.005)
AvgPatentFamilySize	0.028 (0.001)	0.041 (0.028)	0.028 (0.001)	0.041 (0.027)
Avg5-YrFwdCitations	0.00048 (0.048)	0.0031 (0.011)	0.00047 (0.051)	0.0031 (0.011)
RatioInternaltoExternalPatents	0.013 (0.399)	-0.029 (0.281)	0.013 (0.397)	-0.029 (0.282)
NumComponents	-0.000028 (0.572)	0.00013 (0.066)	-0.000026 (0.595)	0.00012 (0.093)
Constant	1.02 (0.000)	1.17 (0.000)	1.03 (0.000)	1.12 (0.000)
Observations	6984	6954	6984	6954
R^2	0.41	0.47	0.41	0.47
Adjusted R^2	0.33	0.40	0.33	0.40
Year_Firm_FE	Yes	Yes	Yes	Yes

Note: OLS Regressions. Unit of observation is firm-year. p-values reported in parentheses
Standard errors clustered at the firm level and robust to arbitrary heteroskedasticity.
All independent variables lagged by one year.

Table 3: Breadth of Search and Impact as a function of Centralization/Decentralization of R&D function

	(1)	(2)	(3)	(4)
	Originality	Generality	Originality	Generality
BudgetCentralization	0.063 (0.057)	0.088 (0.009)		
IncreasedBudgetCentralization (0,1)			0.077 (0.004)	0.096 (0.001)
DecreasedBudgetCentralization (0,-1)			-0.017 (0.671)	-0.014 (0.920)
ln(Sales)	0.0017 (0.761)	-0.0047 (0.746)	0.0016 (0.772)	-0.0049 (0.734)
ln(Assets)	-0.0016 (0.851)	-0.025 (0.226)	-0.0019 (0.822)	-0.025 (0.211)
ln(Employees)	-0.019 (0.084)	-0.00092 (0.968)	-0.019 (0.087)	-0.00045 (0.984)
ln(R&D)	0.0055 (0.360)	0.017 (0.370)	0.0060 (0.313)	0.019 (0.332)
PatentCount	0.0053 (0.244)	-0.0016 (0.862)	0.0055 (0.231)	-0.0011 (0.902)
AvgNonPatentReferences	0.0056 (0.000)	0.0039 (0.249)	0.0056 (0.000)	0.0039 (0.249)
RatioInternaltoExternalPatents	0.049 (0.025)	0.0068 (0.844)	0.050 (0.025)	0.0072 (0.836)
Avg5-YrFwdCitations	0.00058 (0.019)	0.0034 (0.000)	0.00059 (0.018)	0.0035 (0.000)
AvgPatentFamilySize	0.012 (0.129)	0.057 (0.003)	0.012 (0.126)	0.057 (0.003)
NumComponents	-0.000 (0.847)	0.000 (0.353)	-0.000 (0.815)	0.000 (0.374)
Constant	0.96 (0.000)	1.00 (0.000)	0.96 (0.000)	0.99 (0.000)
Observations	6845	6837	6645	6637
R^2	0.48	0.51	0.48	0.51
Adjusted R^2	0.43	0.47	0.43	0.47
Year and Firm FE	Yes	Yes	Yes	Yes

Note: OLS Regressions. Unit of observation is firm-year. p-values reported in parentheses
Standard errors clustered at the firm level and robust to arbitrary heteroskedasticity.
independent variables lagged by one year.

Table 4: Network Structure as Mediator for Budget Centralization. We explore how the relationship between budget structure and outputs may be mediated by the evolution of the firm's co-invention network. Multilevel modeling mediation analyses use the `ml_mediate` package developed by UCLA's Institute for Digital Research and Education (IDRE). This set of routines implement the methodology of Krull and MacKinnon (2001). Iterative Empirical Bayes/maximum likelihood (EB/ML) used, and standard errors are bootstrapped with 5000 replications.

Panel A: Mediation of increased centralization				
	DV: Originality MV: Giant	DV: Generality MV: Giant	DV: Originality MV: Entropy	DV: Generality MV: Entropy
Indirect effect	0.010 (0.000)	0.016 (0.041)	0.012 0.014	0.012 0.039
Direct effect	0.067 (0.005)	0.080 (0.023)	0.068 (0.031)	0.084 (0.032)
Total effect	0.077 (0.000)	0.096 (0.000)	0.077 (0.000)	0.096 (0.000)
Proportion of total mediated (indirect effect / total effect)	0.131	0.172	0.159	0.129

Panel B: Mediation of decreased centralization				
	DV: Originality MV: Giant	DV: Generality MV: Giant	DV: Originality MV: Entropy	DV: Generality MV: Entropy
Indirect effect	-0.001 (0.862)	-0.002 (0.854)	-0.002 0.815	-0.004 0.629
Direct effect	-0.016 (0.601)	-0.012 (0.928)	-0.015 0.614	-0.010 0.936
Total effect	-0.017 (0.671)	-0.014 (0.920)	-0.017 (0.671)	-0.014 (0.920)
Proportion of total mediated (indirect effect / total effect)	0.087	0.112	0.1176	0.286

Table 5: Discrete DV estimations: Dummy for “Changers” Impact on Network

	(1) (centralize) Giant	(2) (centralize) Entropy	(3) (decentralize) Giant	(4) (decentralize) Entropy
Centralizer*After	0.25 (0.000)	-0.15 (0.000)		
Decentralizer*After			0.070 (0.452)	0.054 (0.416)
After	-0.025 (0.076)	0.024 (0.012)	-0.024 (0.079)	0.024 (0.013)
ln(Sales)	-0.026 (0.052)	0.020 (0.039)	-0.023 (0.089)	0.019 (0.050)
ln(Assets)	0.023 (0.163)	-0.019 (0.104)	0.023 (0.153)	-0.020 (0.094)
ln(Employees)	-0.0057 (0.783)	0.0017 (0.906)	-0.012 (0.563)	0.0066 (0.650)
ln(R&D)	0.0016 (0.897)	0.00034 (0.969)	-0.00026 (0.984)	0.00013 (0.988)
PatentCount	0.0061 (0.415)	-0.012 (0.026)	0.0060 (0.424)	-0.012 (0.029)
AvgNonPatentReferences	0.0040 (0.063)	-0.0033 (0.038)	0.0039 (0.066)	-0.0033 (0.035)
RatioInternaltoExternalPatents	0.0089 (0.697)	-0.0026 (0.869)	0.0084 (0.714)	-0.0030 (0.852)
Avg5-YrFwdCitations	0.00033 (0.524)	-0.00047 (0.234)	0.00031 (0.545)	-0.00047 (0.236)
AvgPatentFamilySize	0.00082 (0.927)	-0.0062 (0.351)	0.00053 (0.953)	-0.0064 (0.340)
NumComponents	-0.000 (0.750)	0.000 (0.191)	-0.000 (0.770)	0.000 (0.254)
Constant	0.32 (0.000)	0.61 (0.000)	0.32 (0.000)	0.61 (0.000)
Observations	4575	4575	4244	4244
R^2	0.59	0.69	0.58	0.69
Adjusted R^2	0.55	0.66	0.55	0.66
Year and Firm FE	Yes	Yes	Yes	Yes

Note: OLS Regressions. Unit of observation is firm-year. p-values reported in parentheses
Standard errors clustered at the firm level and robust to arbitrary heteroskedasticity.
All independent variables lagged by one year.

Table 6: Firmlevel Structure Impact on Network and Patenting (yearly)

	(1) (centralize) Giant	(2) (centralize) Entropy	(3) (centralize) Generality	(4) (centralize) Originality
Year post-change 1	0.11 (0.118)	-0.056 (0.109)	0.0094 (0.191)	0.059 (0.144)
Year post-change 2	0.14 (0.074)	-0.10 (0.082)	0.0040 (0.098)	0.057 (0.071)
Year post-change 3	0.16 (0.009)	-0.072 (0.015)	0.012 (0.011)	0.083 (0.008)
Year post-change 4	0.20 (0.005)	-0.11 (0.009)	0.028 (0.009)	0.094 (0.006)
Year post-change 5	0.18 (0.002)	-0.12 (0.004)	0.041 (0.003)	0.11 (0.055)
Year post-change 6	0.20 (0.002)	-0.12 (0.008)	0.040 (0.001)	0.12 (0.005)
Year post-change 7	0.21 (0.007)	-0.14 (0.004)	0.036 (0.002)	0.070 (0.004)
Year post-change 8	0.21 (0.008)	-0.16 (0.002)	0.041 (0.000)	0.11 (0.001)
Year post-change 9	0.19 (0.001)	-0.18 (0.003)	0.040 (0.003)	0.13 (0.005)
ln(Sales)	-0.032 (0.001)	0.034 (0.000)	0.00024 (0.969)	-0.011 (0.483)
ln(Assets)	0.0081 (0.557)	-0.013 (0.272)	-0.0065 (0.512)	-0.012 (0.579)
ln(Employees)	0.0071 (0.627)	-0.0069 (0.564)	-0.031 (0.019)	0.00035 (0.989)
ln(R&D Expense)	-0.0071 (0.402)	-0.0041 (0.563)		0.0088 (0.786)
PatentsCount	-0.025 (0.003)	0.013 (0.034)	0.011 (0.077)	-0.020 (0.071)
AvgNonPatentReferences	0.0095 (0.001)	-0.0078 (0.002)	0.0045 (0.061)	0.012 (0.011)
AvgPatentFamilySize	0.029 (0.018)	-0.040 (0.000)	0.014 (0.157)	0.054 (0.069)
Avg5-YrFwdCitations	0.0018 (0.000)	-0.0015 (0.000)	0.00100 (0.009)	0.0041 (0.000)
RatioInternaltoExternalPatents	0.056 (0.011)	-0.037 (0.029)	0.061 (0.010)	0.0085 (0.822)
NumComponents	0.000 (0.983)	0.000 (0.413)	0.000 (0.479)	0.000 (0.018)
Observations	4348	4348	4235	4231
R^2	0.31	0.34	0.51	0.53
Adjusted R^2	0.30	0.33	0.45	0.47
Year and Firm FE	Yes	Yes	Yes	Yes

Note: OLS Regressions. Unit of observation is firm-year. p-values reported in parentheses. Standard errors clustered at the firm level and robust to arbitrary heteroskedasticity. All independent variables other than annual spells lagged by one year.

Table 7: Appendix: Bivariate Correlation Table

	Mean	SD	Min	Max	(1)	(2)	(3)	(4)	(5)	(6)	(7)	(8)	(9)	(10)	(11)	(12)	(13)	(14)	(15)	
(1) Originality	0.74	0.09	0.000	0.962	1.00															
(2) Generality	0.49	0.11	0.000	0.876	0.32 (0.00)	1.00														
(3) Centralization	0.00	0.10	-0.800	1.000	0.01 (0.18)	0.01 (0.27)	1.00													
(4) Entropy	0.33	0.23	0.015	1.000	-0.12 (0.00)	-0.13 (0.00)	0.01 (0.25)	1.00												
(5) Giant	0.57	0.18	0.000	0.947	0.11 (0.00)	0.11 (0.00)	-0.00 (0.61)	-0.73 (0.00)	1.00											
(6) Sales	9671	17624	0.000	255112	-0.01 (0.32)	-0.01 (0.07)	0.13 (0.00)	0.02 (0.03)	-0.05 (0.00)	1.00										
(7) Assets	11258	39754	2.794	797769	-0.00 (0.57)	-0.00 (0.73)	0.11 (0.00)	-0.02 (0.01)	0.00 (0.83)	0.83 (0.00)	1.00									
(8) Employees	33.78	62.26	0.060	876.800	-0.02 (0.03)	-0.02 (0.00)	0.10 (0.00)	0.13 (0.00)	-0.16 (0.00)	0.77 (0.00)	0.66 (0.00)	1.00								
(9) R&D	402	1004	3.719	12183	-0.01 (0.08)	-0.02 (0.00)	0.20 (0.00)	-0.01 (0.43)	-0.04 (0.00)	0.68 (0.00)	0.59 (0.00)	0.62 (0.00)	1.00							
(10) PatCount	145	298	5.000	10246	-0.02 (0.00)	-0.03 (0.00)	0.10 (0.00)	-0.02 (0.00)	0.01 (0.43)	0.45 (0.00)	0.40 (0.00)	0.47 (0.00)	0.54 (0.00)	1.00						
(11) NPL	1.98	15.88	0	246	0.11 (0.00)	0.09 (0.00)	0.00 (0.87)	-0.12 (0.00)	0.11 (0.00)	-0.02 (0.02)	-0.01 (0.06)	-0.03 (0.00)	-0.02 (0.02)	-0.02 (0.01)	1.00					
(12) IntRatio	0.70	0.33	0.000	1.000	0.01 (0.32)	0.00 (0.61)	-0.00 (0.80)	-0.11 (0.00)	0.11 (0.00)	0.00 (0.94)	0.01 (0.15)	-0.01 (0.05)	-0.04 (0.00)	-0.01 (0.07)	-0.02 (0.01)	1.00				
(13) 5yr cites	3.78	11.33	0.000	198	0.05 (0.00)	0.12 (0.00)	0.00 (0.48)	-0.17 (0.00)	0.15 (0.00)	-0.01 (0.44)	-0.00 (0.95)	-0.02 (0.01)	0.03 (0.00)	0.02 (0.01)	0.12 (0.00)	-0.02 (0.02)	1.00			
(14) Components	46.66	97.41	1	1455	-0.07 (0.00)	-0.05 (0.00)	0.13 (0.00)	0.13 (0.00)	-0.17 (0.00)	0.43 (0.00)	0.36 (0.00)	0.51 (0.00)	0.52 (0.00)	0.69 (0.00)	-0.06 (0.00)	0.03 (0.00)	-0.01 (0.07)	1.00		
(15) Family Size	4.81	3.65	1.000	39	0.07 (0.00)	0.10 (0.00)	0.01 (0.35)	-0.14 (0.00)	0.10 (0.00)	0.02 (0.01)	0.01 (0.09)	0.00 (0.92)	0.04 (0.00)	-0.02 (0.00)	0.13 (0.00)	-0.04 (0.00)	0.14 (0.00)	-0.05 (0.00)	1.00	

Table 8: Appendix: Replicate Table 1 Limiting Sample to CIMS/IRI Firms Only

	(1)	(2)	(3)	(4)
	Giant	Entropy	Giant	Entropy
BudgetCentralization	0.17 (0.001)	-0.088 (0.010)		
IncreasedBudgetCentralization (0,1)			0.31 (0.000)	-0.13 (0.000)
DecreasedBudgetCentralization (0,-1)			0.015 (0.935)	0.034 (0.866)
ln(Assets)	0.010 (0.803)	0.0051 (0.835)	0.0091 (0.822)	0.0058 (0.812)
ln(Employees)	-0.066 (0.270)	0.044 (0.264)	-0.065 (0.260)	0.043 (0.256)
ln(R&D)	-0.010 (0.655)	-0.00074 (0.962)	-0.012 (0.597)	0.00049 (0.975)
PatentCount	0.022 (0.122)	-0.025 (0.023)	0.022 (0.119)	-0.025 (0.022)
ln(Sales)	0.030 (0.408)	-0.028 (0.359)	0.030 (0.415)	-0.027 (0.363)
AvgNonPatentReferences	0.0031 (0.124)	-0.0020 (0.262)	0.0030 (0.137)	-0.0019 (0.284)
AvgPatentFamilySize	0.012 (0.328)	-0.012 (0.127)	0.012 (0.323)	-0.012 (0.123)
Avg5-YrFwdCitations	0.0012 (0.412)	-0.0013 (0.221)	0.0014 (0.295)	-0.0014 (0.150)
RatioInternaltoExternalPatents	-0.0063 (0.911)	-0.013 (0.760)	-0.0088 (0.874)	-0.011 (0.787)
NumComponents	-0.00014 (0.310)	0.00016 (0.098)	-0.00016 (0.267)	0.00017 (0.079)
ln(Book Value/Share)	-0.010 (0.480)	0.010 (0.285)	-0.0083 (0.563)	0.0088 (0.345)
Constant	0.12 (0.686)	0.75 (0.001)	0.12 (0.702)	0.73 (0.001)
Observations	1448	1448	1448	1448
R^2	0.64	0.72	0.64	0.72
Adjusted R^2	0.60	0.69	0.60	0.69
Year_Firm_FE	Yes	Yes	Yes	Yes

Note: OLS Regressions. Unit of observation is firm-year. p-values reported in parentheses
Standard errors clustered at the firm level and robust to arbitrary heteroskedasticity.
All independent variables lagged by one year.

Table 9: Appendix: Replicate Table 2 Limiting Sample to CIMS/IRI Firms Only

	(1)	(2)	(3)	(4)
	Originality	Generality	Originality	Generality
Giant			0.087 (0.031)	0.074 (0.046)
Entropy	-0.048 (0.062)	-0.14 (0.047)		
ln(Sales)	0.040 (0.050)	0.057 (0.159)	0.040 (0.054)	0.059 (0.143)
ln(Assets)	-0.021 (0.166)	-0.050 (0.067)	-0.020 (0.177)	-0.051 (0.060)
ln(Employees)	-0.033 (0.020)	-0.0079 (0.739)	-0.033 (0.021)	-0.0096 (0.678)
ln(R&D Expense)	0.019 (0.121)	0.018 (0.582)	0.019 (0.121)	0.019 (0.572)
PatentsCount t-1	0.0055 (0.176)	0.010 (0.424)	0.0052 (0.210)	0.012 (0.363)
AvgNonPatentReferences	0.0063 (0.000)	0.0059 (0.050)	0.0063 (0.000)	0.0060 (0.050)
AvgPatentFamilySize	0.0088 (0.495)	0.00086 (0.967)	0.0086 (0.500)	0.0016 (0.939)
Avg5-YrFwdCitations	0.0018 (0.040)	0.013 (0.000)	0.0018 (0.041)	0.013 (0.000)
RatioInternaltoExternalPatents	-0.023 (0.303)	0.024 (0.715)	-0.024 (0.295)	0.025 (0.705)
NumComponents	-0.000069 (0.200)	-0.00011 (0.405)	-0.000067 (0.210)	-0.00011 (0.367)
Constant	0.83 (0.000)	0.82 (0.000)	0.86 (0.000)	0.76 (0.000)
Observations	1471	1465	1471	1465
R^2	0.40	0.45	0.40	0.45
Adjusted R^2	0.35	0.40	0.35	0.40
Year_Ind_Firm_FE				

Note: OLS Regressions. Unit of observation is firm-year. p-values reported in parentheses
Standard errors clustered at the firm level and robust to arbitrary heteroskedasticity.
All independent variables lagged by one year.

Table 10: Appendix: Replicate Table 3 Limiting Sample to CIMS/IRI Firms Only

	(1)	(2)	(3)	(4)
	Originality	Generality	Originality	Generality
BudgetCentralization	0.059 (0.001)	0.062 (0.004)		
IncreasedBudgetCentralization (0,1)			0.081 (0.007)	0.089 (0.004)
DecreasedBudgetCentralization (0,-1)			-0.13 (0.000)	-0.023 (0.755)
ln(Assets)	-0.018 (0.180)	-0.056 (0.042)	-0.019 (0.157)	-0.057 (0.041)
ln(Employees)	-0.033 (0.020)	0.0053 (0.856)	-0.032 (0.025)	0.0057 (0.845)
ln(R&D)	0.017 (0.055)	0.025 (0.177)	0.015 (0.076)	0.024 (0.184)
PatentCount	0.0054 (0.256)	0.011 (0.266)	0.0058 (0.224)	0.011 (0.261)
ln(Sales)	0.038 (0.024)	0.037 (0.293)	0.037 (0.027)	0.036 (0.296)
AvgNonPatentReferences	0.0067 (0.000)	0.0090 (0.000)	0.0066 (0.000)	0.0090 (0.001)
AvgPatentFamilySize	0.011 (0.067)	0.024 (0.064)	0.012 (0.061)	0.024 (0.063)
RatioInternaltoExternalPatents	-0.034 (0.085)	-0.024 (0.567)	-0.037 (0.064)	-0.024 (0.555)
NumComponents	-0.000043 (0.413)	-0.000068 (0.527)	-0.000052 (0.313)	-0.000071 (0.510)
ln(Book Value/Share)	0.0067 (0.213)	0.020 (0.075)	0.0082 (0.128)	0.020 (0.070)
Constant	0.85 (0.000)	0.97 (0.000)	0.99 (0.000)	0.99 (0.000)
Observations	1448	1442	1448	1442
R^2	0.41	0.45	0.41	0.45
Adjusted R^2	0.36	0.40	0.36	0.39
Year_Firm_FE	Yes	Yes	Yes	Yes

Note: OLS Regressions. Unit of observation is firm-year. p-values reported in parentheses
Standard errors clustered at the firm level and robust to arbitrary heteroskedasticity.
All independent variables lagged by one year.